

Product Catalogue
Vertical Formwork

FS tifa-flex



FS form-scaff

Formwork & Scaffolding
Solutions

We are
WACO



Form-Scaff is South Africa's leading supplier of formwork, falsework and scaffolding to the construction and civil engineering industries. Form-Scaff not only manufactures, hires and sells world-class products, but also provides the design skills, technical advice and support that comes with having 50 years experience and more than 30 branches locally and internationally.

We are Waco International

Form-Scaff is part of Waco International, a focused equipment rental and industrial services business with operations in Africa (South Africa and other sub-Saharan African countries), Australasia (Australia and New Zealand) and the United Kingdom.

The Group provides services in the areas of formwork, shoring and scaffolding, insulation, painting and blasting, hydraulics and suspended access platforms, relocatable modular buildings, portable sanitation products and integrated hygiene services.

Disclaimer:

Copyright in this catalogue vests in Form-Scaff, a division of Waco Africa (Proprietary) Limited ("Form-Scaff") and extends inter alia, to the making of copies in whole or in part without the prior written consent of Form-Scaff.

While every effort has been made to ensure the accuracy of the information in this catalogue, we cannot accept responsibility for any errors which may occur as a result of reliance on the contents of this catalogue and are not liable for any loss of any nature that may be incurred as a result of such reliance. Details of any of the products may change without prior notice.

The customer must ensure that 'good practice' is adopted on site by competent persons and that the products shown in this catalogue are erected, used and stripped in accordance with the relevant Codes of Practice and the OHS Act and Regulations 85 of 1993. This catalogue does not contain any design detail but lists and depicts the items available under this product range. The responsibility for design is the responsibility of the customer.

Note: The colours used in this document are for illustrative purposes only and may differ on actual products

Contents



- Page 2** Tifa-Flex Overview
- Page 3** General Assembly
- Page 4** Panels
- Page 5** Walers
- Page 6** Ties
- Page 8** Clamps & Brackets
- Page 9** Propping & Levelling
- Page 10** Access
- Page 11** Infills
- Page 12** Splicing
- Page 13** Stop-ends
- Page 14** Lifting
- Page 16** Circular to Straight

- Contact Details**
- Page 17** Head Office & Branches

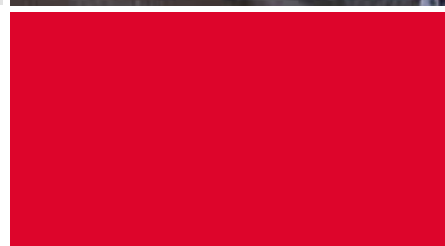
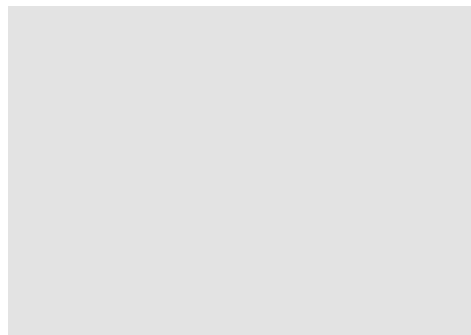
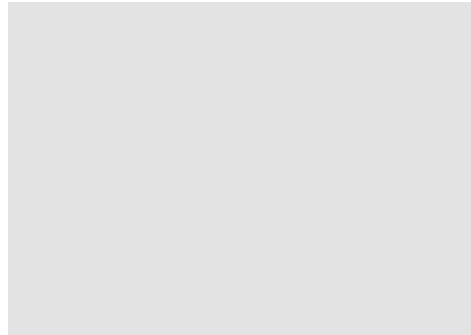



tifa-flex



Tifa-Flex Walls

Tifa-Flex is a new generation heavy duty crane handled wall formwork solution for concrete walls with a radius exceeding 5m.

By simply adjusting a series of turnbuckles on the back of the panels, one can very quickly create any concave or convex shape that may be required to form circular concrete structures such as tanks and reservoirs.

System Features

- The system is able to resist a concrete pressure of 60 kN/m².
- The Panels are available in heights of 3000 and 1500mm and in widths of 2400, 1200 and 600mm.
- Panels can be gang-formed up to 6m in height and up to a maximum panel size of 14.4m².
- The system includes safe working platforms complete with a push-pull plumbing arrangement.



tifa-flex

General Assembly

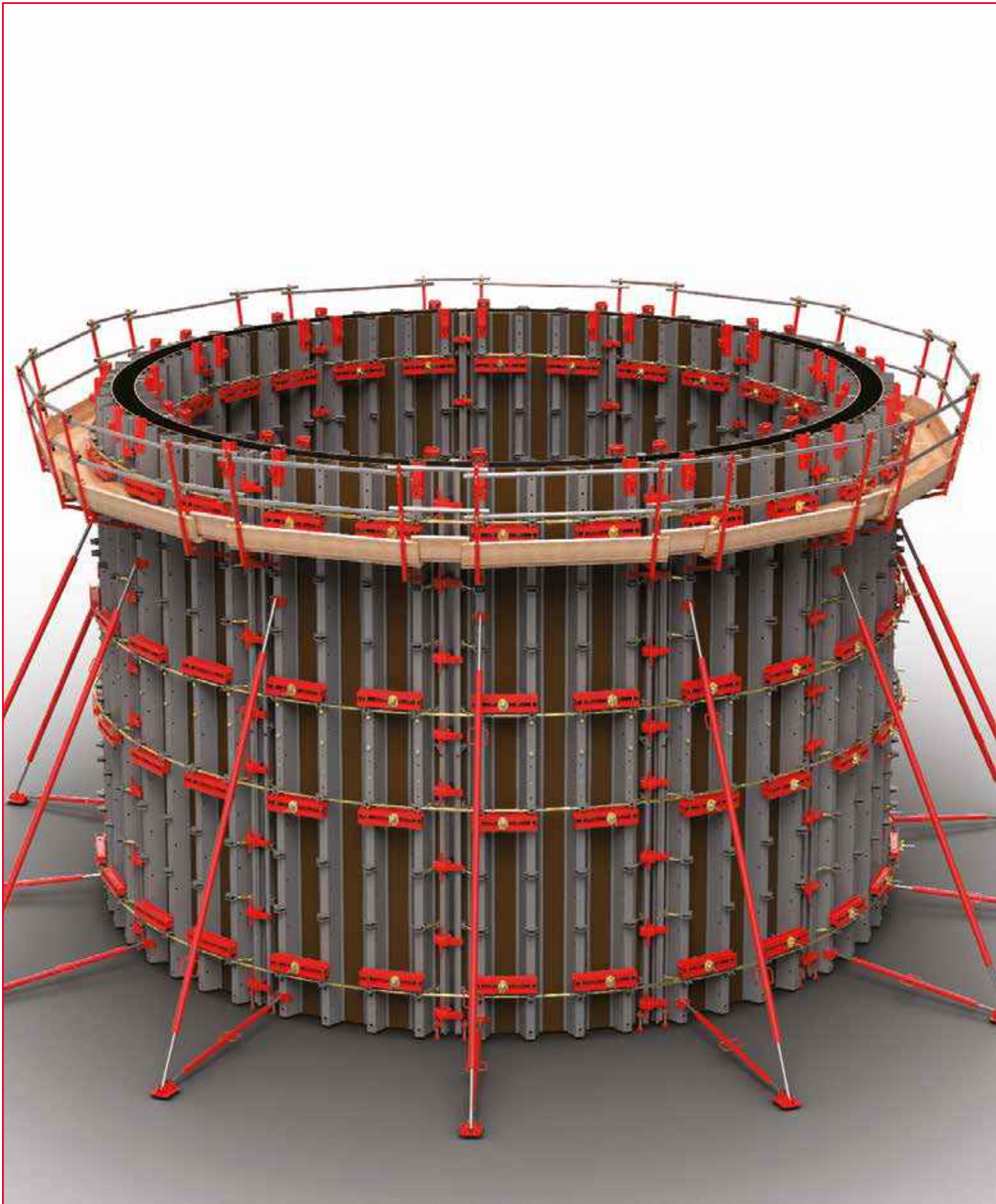

Panels

Tifa-Flex Panels are used to form circular concrete walls.

CODE	DESCRIPTION	MASS(kg)
9152020	TIFA-FLEX PANEL 3000 X 2400	696.9
9152021	TIFA-FLEX PANEL 3000 X 1200	398.1
9152022	TIFA-FLEX PANEL 3000 X 600	248.2
9152023	TIFA-FLEX PANEL 1500 X 2400	350.3
9152024	TIFA-FLEX PANEL 1500 X 1200	200.7
9152025	TIFA-FLEX PANEL 1500 X 600	125.7



Turnbuckles

Tifa-Flex Panel and Periphery Turnbuckles are used to adjust and maintain the required radius of the Panel facing.

CODE	DESCRIPTION	MASS(kg)
9152027	TIFA-FLEX INFILL TURNBUCKLE 650	4.6
9152014	TIFA-FLEX INFILL TURNBUCKLE 470	3.3
9152004	TIFA-FLEX PANEL TURNBUCKLE 370	3.0
9152005	TIFA-FLEX PERIPHERY TURNBUCKLE 100	1.2



Turnbuckle Pins and R-Clips

Tifa-Flex Turnbuckle Pins and R-Clips are used to connect the Turnbuckles to the Tifa-Flex Panels.

CODE	DESCRIPTION	MASS(kg)
9152051	TIFA-FLEX TURNBUCKLE PIN 16 X 62	0.2
9152053	R-CLIP 78 X 4	0.01



Walers

Tifa-Flex Walers are placed behind the Tifa-Flex Panels in all tie positions to create a flat bearing surface for the Dywidag Tie system.

CODE	DESCRIPTION	MASS(kg)
9152007	TIFA-FLEX WALER 810	25.2



Waler Pins and R-Clips

Tifa-Flex Waler Pins and R-Clips are used to connect the Tifa-Flex Walers to the back of the Tifa-Flex Panels.

CODE	DESCRIPTION	MASS(kg)
9152050	TIFA-FLEX WALER PIN 24 X 93	0.5
9152054	R-CLIP 104 X 5	0.01



Application - Walers and Turnbuckles

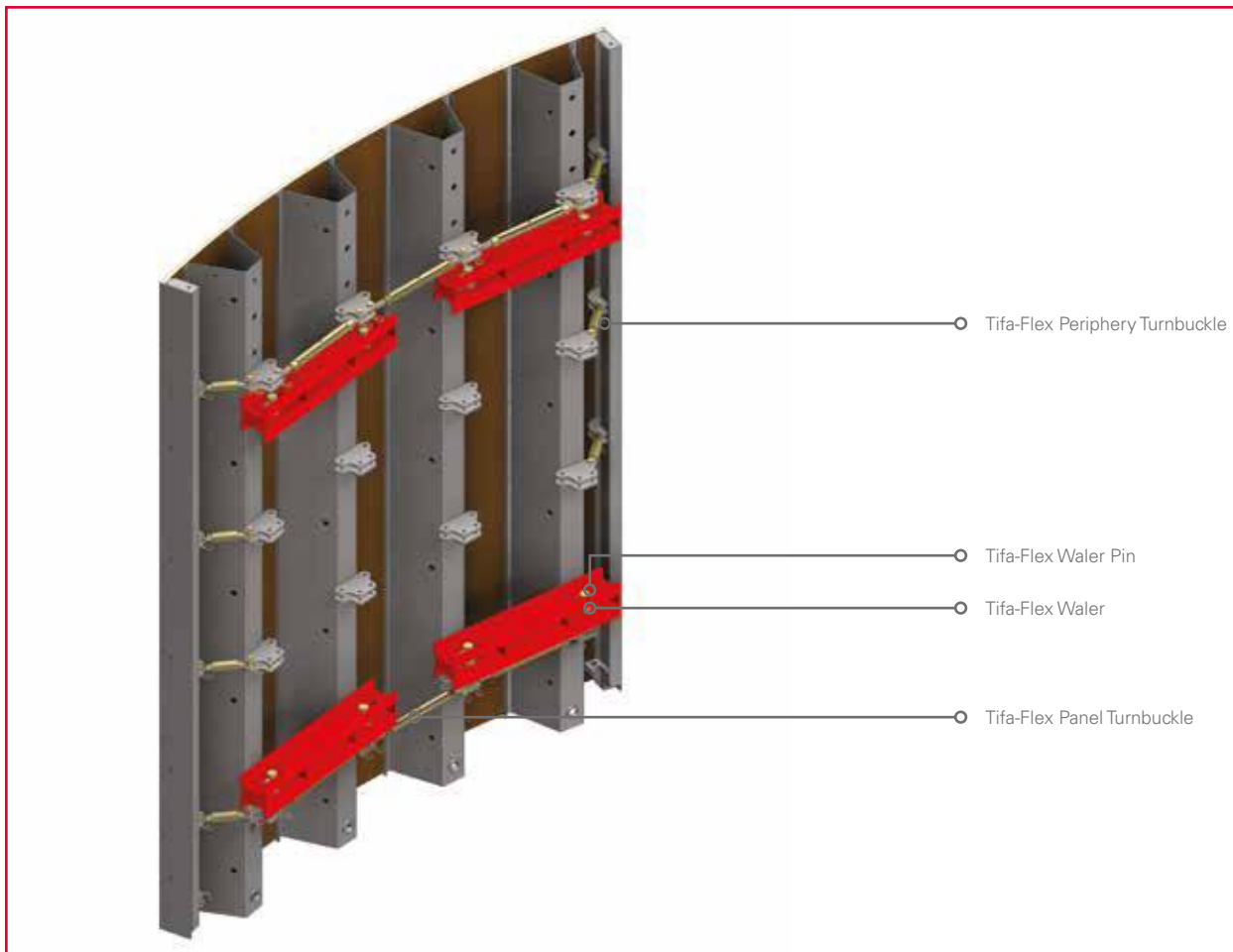

Dywidag Ties

The Tifa-Flex system uses either the 15mm or 20mm Dywidag Tie system depending on the concrete pressure. Ties are available in increments of 500mm. The Dywidag Spanners are used to prevent the tie from turning when tightening / loosening the Combi Wing Nuts.

CODE	DESCRIPTION	MASS(kg)
5405085	DYWIDAG BAR 15MM 2000	2.9
5405079	DYWIDAG BAR 15MM 1500	2.2
5405078	DYWIDAG BAR 15MM 1000	1.5
5110150	DYWIDAG COMBI WING NUT 15 DIA.	1.1
5405098	DYWIDAG TIE SPANNER 15MM	1.1
9153003	DYWIDAG BAR 20MM 2000	5.1
9153002	DYWIDAG BAR 20MM 1500	3.8
9153001	DYWIDAG BAR 20MM 1000	2.6
9153020	DYWIDAG COMBI WING NUT 20 DIA.	1.6
5405115	DYWIDAG TIE SPANNER 20MM	1.1



Ferrule Tubes & Cones

PVC Ferrule Tubes and Cones are used in conjunction with the Dywidag Ties on the Tifa-Flex system.

CODE	DESCRIPTION	MASS(kg)
5520372	PVC FERRULE TUBE 22 ID & 25 OD	0.01
5520382	PVC FERRULE TUBE CONE 22 OD	0.01
5520370	PVC FERRULE TUBE 26 ID & 30 OD	0.01
5520380	PVC FERRULE TUBE CONE 26 OD	0.01



Top-Tie Brackets

Tifa-Flex Top-Tie Brackets connect onto the Trapezoidal Soldier to attach the Access Bracket, to provide top-tie positions for the system and to allow for Panel lifting.

CODE	DESCRIPTION	MASS(kg)
9152013	TIFA-FLEX TOP-TIE BRACKET	7.5
9152011	TIFA-FLEX M24 X 40 GR 8.8 SET SCREW	0.4
2966057	M24 WASHER	0.02
2966059	M24 NUT GR 8.8	0.1





Application - Ties

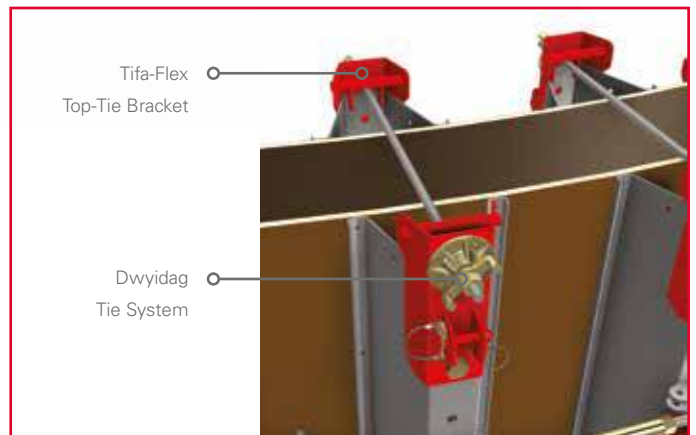
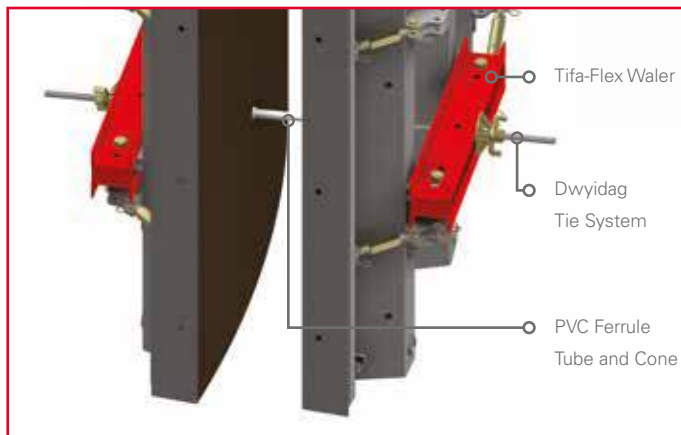
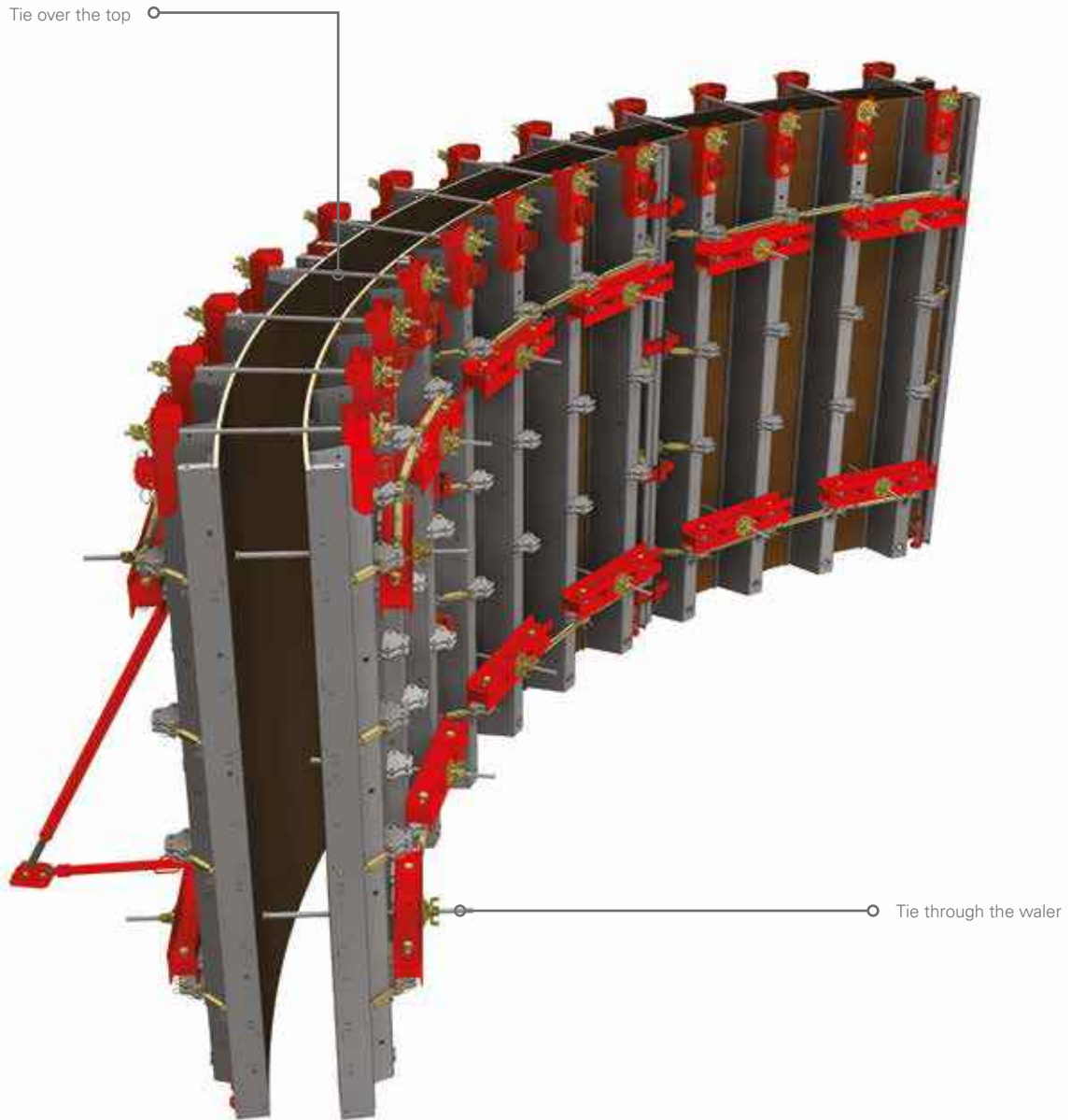

Clamps & Brackets

Fixed Clamps

Tifa Fixed Clamps are used to connect two Tifa-Flex Panels side by side. They are also used to clamp Tifa-Flex Panels to FTS Panels.

CODE	DESCRIPTION	MASS(kg)
5110001	TIFA FIXED CLAMP	4.8



Universal Clamps

Tifa Universal Clamps are used to connect two Tifa-Flex Panels together side by side where an infill is required between the Tifa-Flex Panels.

CODE	DESCRIPTION	MASS(kg)
5110170	TIFA UNIVERSAL CLAMP	7.6



Connecting Brackets

Tifa-Flex Connecting Brackets are attached to the Panel's Trapezoidal Soldiers to allow the connecting of Push-Pull Props, Push-Pull Prop Ties and Access Brackets.

CODE	DESCRIPTION	MASS(kg)
9152010	TIFA-FLEX CONNECTING BRACKET	3.0



Application - Clamps

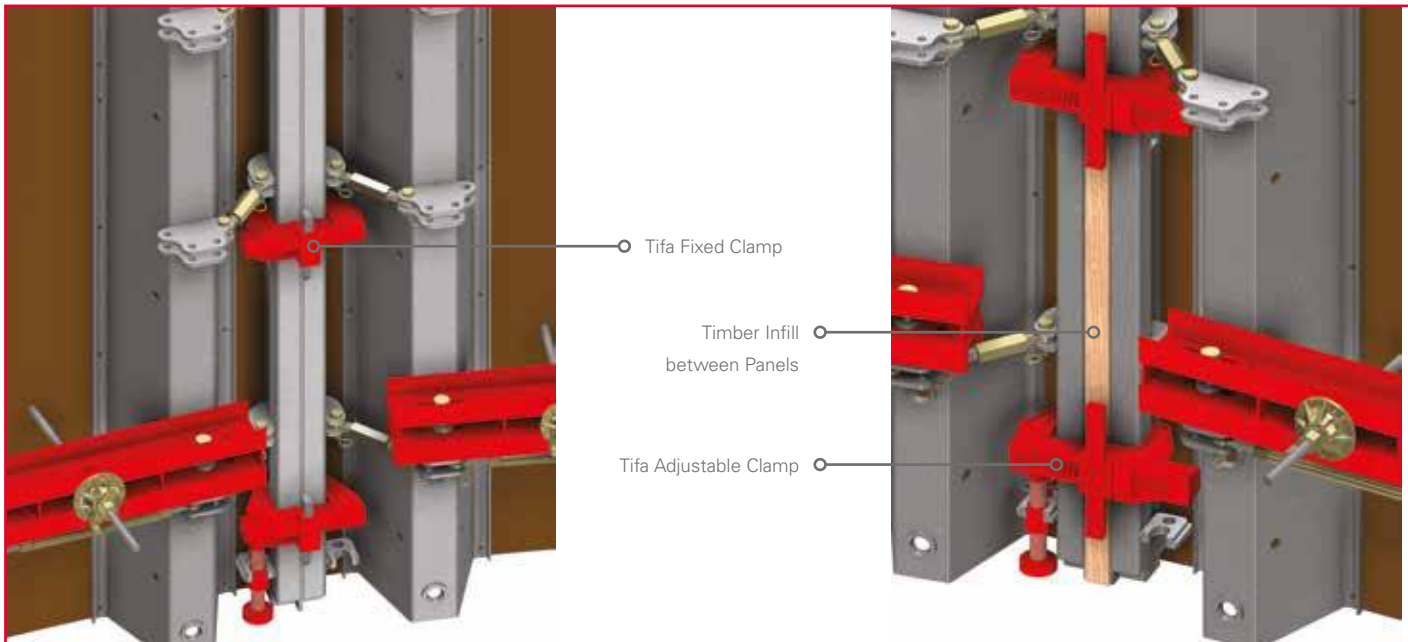

Push-Pull Props

Push-Pull Props and Push-Pull Prop Ties are used to plumb the Tifa-Flex Panels.

CODE	DESCRIPTION	MASS(kg)
5110022	PUSH-PULL PROP 5700	71.4
5110201	PUSH-PULL PROP 4200	34.2
5110024	PUSH-PULL PROP 3100	23.5
5110007	PUSH-PULL PROP 2500	20.8
5110100	PUSH-PULL PROPTIE	15.7



Swivel Feet

Push-Pull Prop Swivel Feet connects the Push Pull Props and Prop Ties into a Propping assembly. The Swivel Feet can also be bolted down if required.

CODE	DESCRIPTION	MASS(kg)
5110021	PUSH-PULL PROP SWIVEL FOOT 300 X 250	8.0
5110008	PUSH-PULL PROP SWIVEL FOOT 200 X 150	3.5



Pins & R-Clips

Pins and R-Clips are used to secure the Push Pull Props and Prop Ties to both the Tifa-Flex Panels and the Swivel Feet.

CODE	DESCRIPTION	MASS(kg)
5110090	CONNECTING PIN 16 X 90	0.2
5110059	R-CLIP 70 X 3	0.01



Levelling Jacks

TF/MF Levelling Jacks are used to level the top of gang-formed units and are secured to the Panel Periphery using a R-Clip 78 x 4.

CODE	DESCRIPTION	MASS(kg)
9152012	TF/MF LEVELLING JACK	2.7
9152053	R-CLIP 78 X 4	0.01



Access Brackets

TF/MF Access Brackets are secured to the Tifa-Flex Connecting Brackets or Top-Tie Brackets in order to support access platforms, toe-boards and guardrails at the required working height.

CODE	DESCRIPTION	MASS(kg)
9152009	TF/MF ACCESS BRACKET	13.4



Application - Access

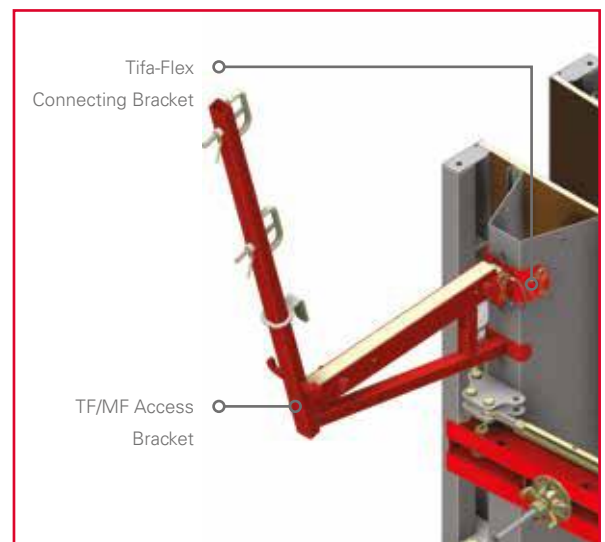
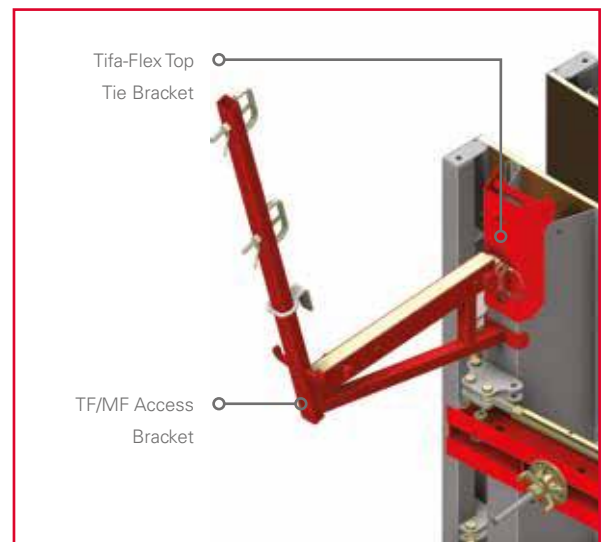

Infill Member

Tifa-Flex Infill Members 1500 are used in conjunction with 21mm thick plywood to make up an infill panel between two Tifa-Flex Panels.

CODE	DESCRIPTION	MASS(kg)
9152015	TIFA-FLEX INFILL MEMBER 1500	8.4



Application - Infills

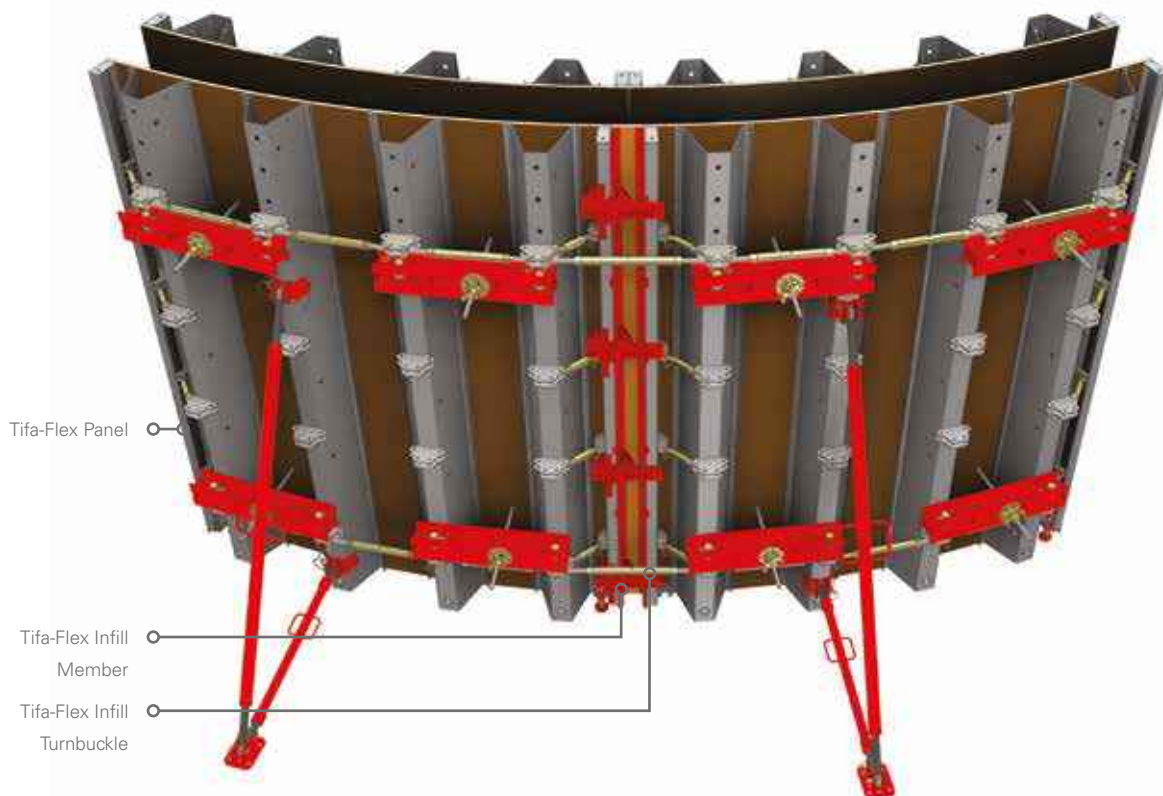
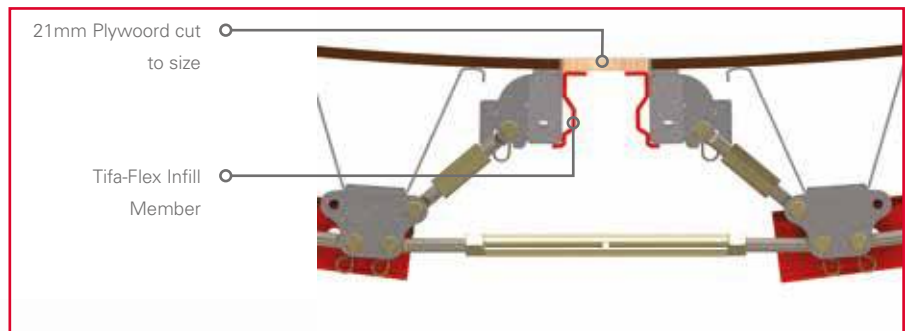

Soldier Splice

The Tifa-Flex Soldier Splices are used to connect two Trapezoidal Soldiers end on end. The Tifa-Flex Soldier Splice can also be used to lift the Tifa-Flex system.

CODE	DESCRIPTION	MASS(kg)
9152002	TIFA-FLEX SOLDIER SPLICE	12.6
9152011	TIFA-FLEX M24 X 40 GR 8.8 SET SCREW	0.3
9152052	TIFA-FLEX M24 X 60 CENTRALIZING BOLT	0.5



Application - Splicing

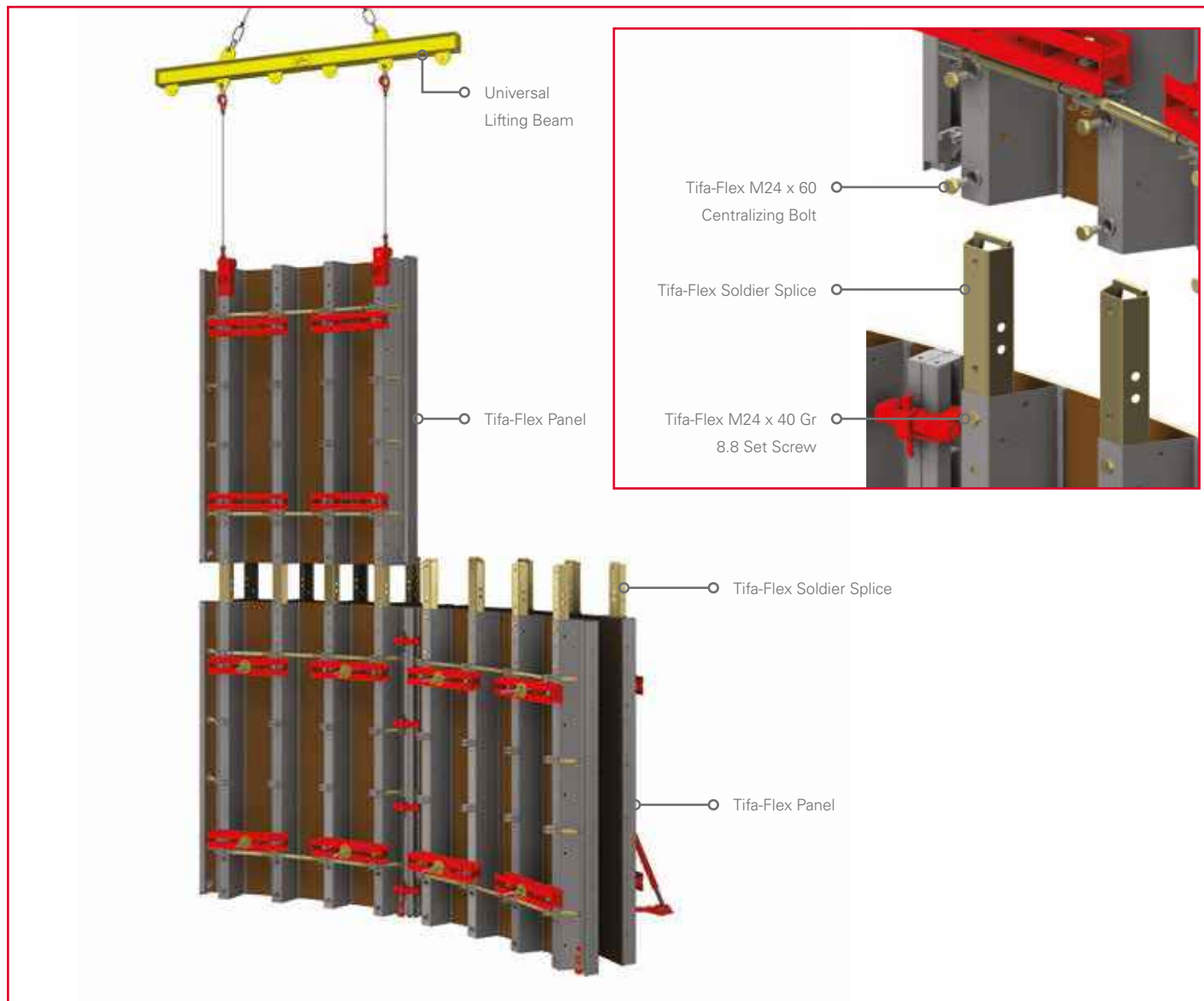

Stop-end Hooks

Tifa Stop-end Hooks are used to secure Multi-Form Walers in position at the stop-end of a concrete wall.

The Dywidag Combi Wing Nut Ø15 is used in conjunction with the Stop-end Hook.



CODE	DESCRIPTION	MASS(kg)
5110206	TIFA STOP-END HOOK	1.7

Walers

Multi-Form Walers are used as horizontal support members in conjunction with Tifa Stop-end Hooks at the stop-end of a concrete wall.

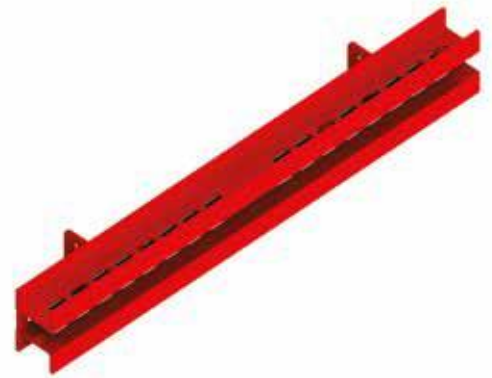

CODE	DESCRIPTION	MASS(kg)
1605074	MULTI-FORM WALER 2400	52.6
1605073	MULTI-FORM WALER 1800	39.1
1605010	MULTI-FORM WALER 1500	32.4
1605072	MULTI-FORM WALER 1200	25.7
1605071	MULTI-FORM WALER 900	19.0
1605025	MULTI-FORM WALER 600	12.6

Application - Stop-ends

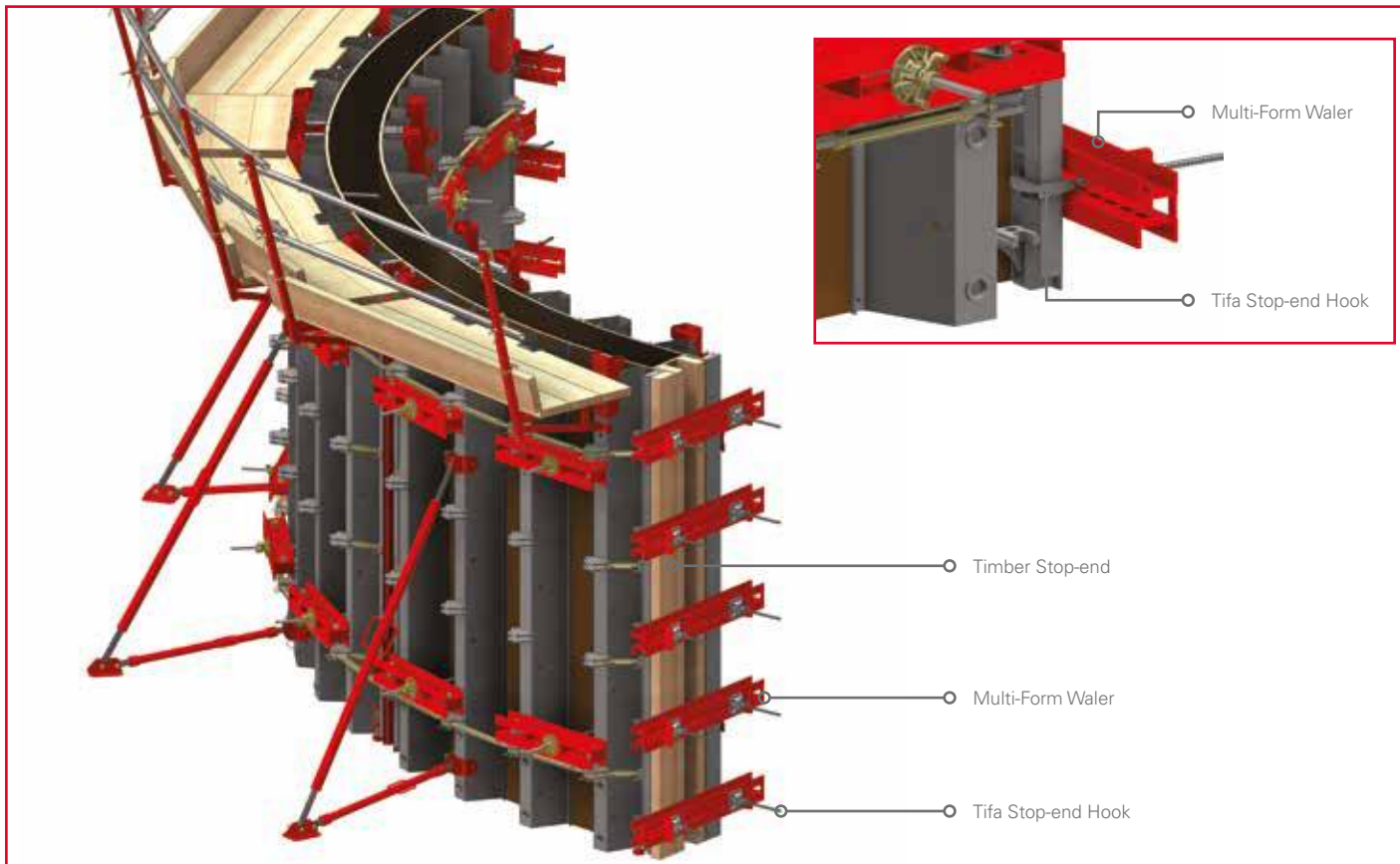

Lifting Beams

Lifting of the Tifa-Flex system is done from the lifting points on either the Tifa-Flex Soldier Splice or the Tifa-Flex Top-Tie Bracket. Universal Lifting Beams are used in conjunction with the Chain Slings to lift the Tifa-Flex system either as individual Panels or in gang-forms up to a maximum of 14.4m².

CODE	DESCRIPTION	MASS(kg)
5110101	UNIVERSAL LIFTING BEAM 3300	170.8
5110103	UNIVERSAL LIFTING BEAM SAFETY CHAIN SHACKLE 4.75 TON	1.1
5110105	UNIVERSAL LIFTING BEAM 10MM GRADE 8 CHAIN X 1250	2.6
5110106	UNIVERSAL LIFTING BEAM 16MM GRADE 8 OBLONG LINK	0.7



Application - Lifting

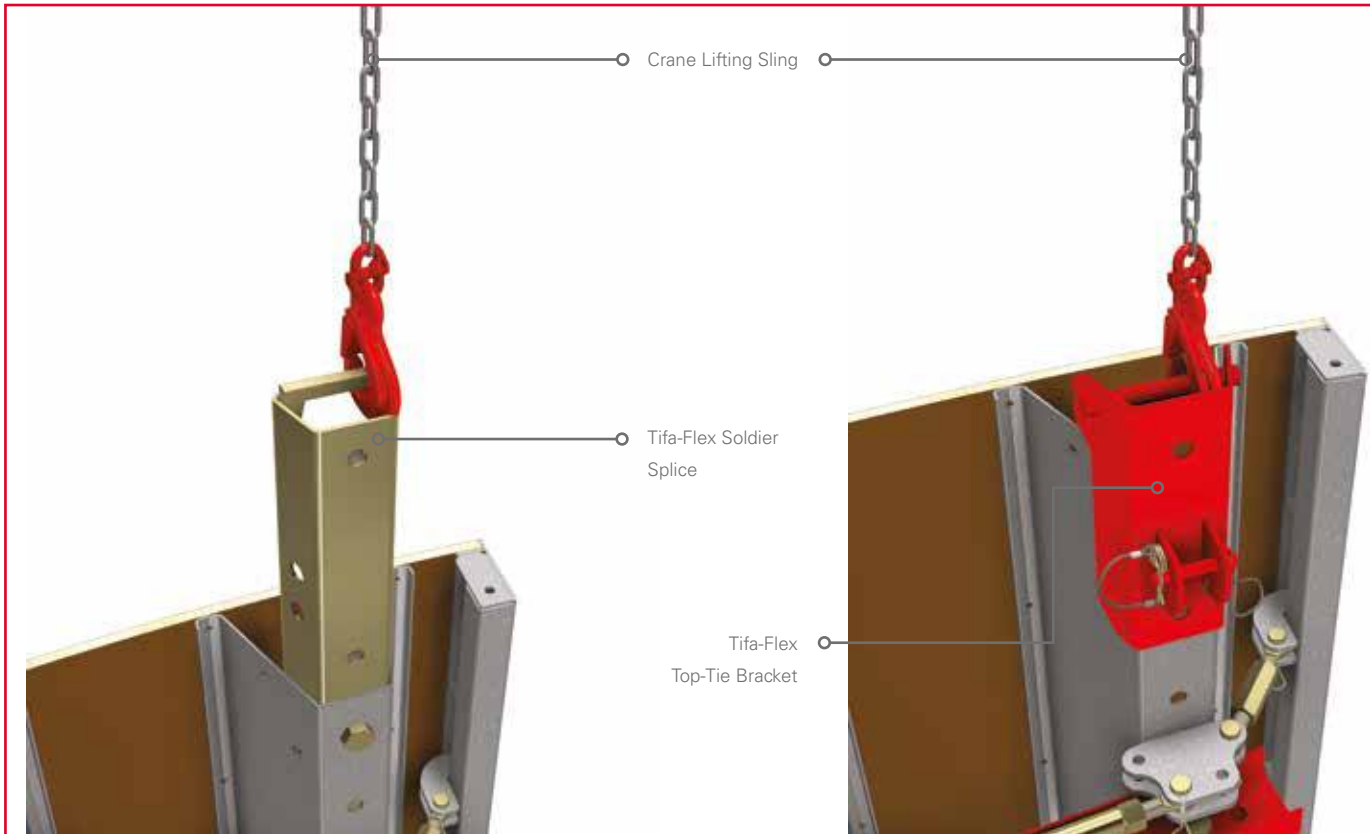

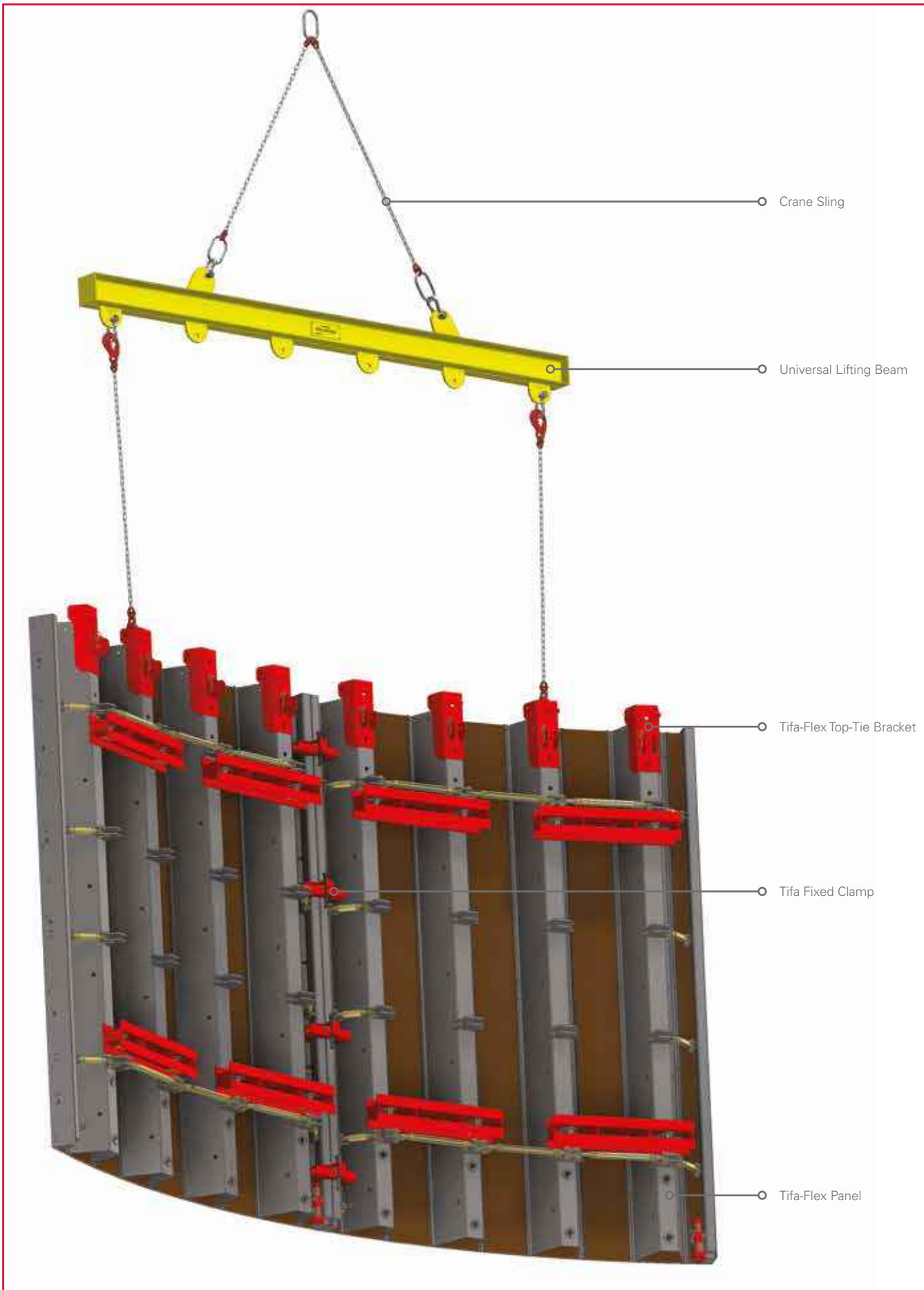

Circular to Straight

FTS Panels

Tifa-Flex FTS Panels are used to connect Tifa-Flex Panels to Tifa Panels allowing a smooth transition from circular walls to straight walls. For a complete list of available Tifa Panel sizes and accessories, please see our Tifa Product Catalogue.

CODE	DESCRIPTION	MASS(kg)
9152055	TIFA-FLEX FTS PANEL 1500	59.4



Application - Circular to Straight

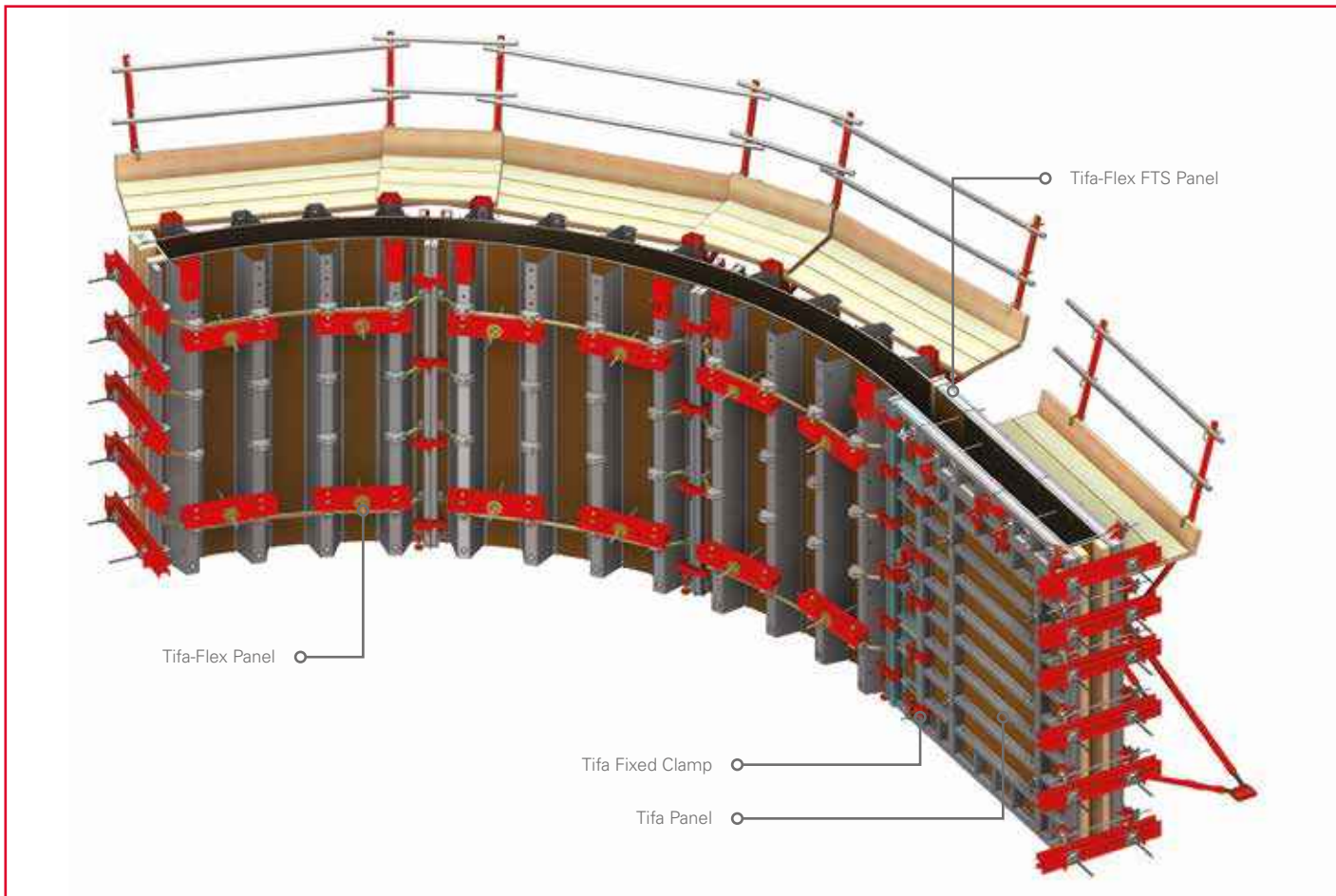

International Branches

Ghana - Accra

Plot 29, Off Spintex Road, Tema
Motorway Industrial Area,
Accra, Ghana
Tel +233 30397 3722 /
+233 20868 1651

Kenya - Nairobi

Plot 15081/5/27 Old Airport North
Road, Nairobi, Kenya
Tel +254 724 004 781 /
+254 718 220 412

Mauritius - Port Louis

Anse Courtois Street, Montebello,
Pailles, Mauritius
Tel +230 286 6175 /
+230 5940 2551

Mozambique - Palma

N'Cumbi Road No. R762,
Palma, Mozambique
Tel +258 86 109 6443 /
+258 84 774 3788

Mozambique - Pemba

Estrada Nacional EN106, Muxara,
Pemba, Cabo Delgado, Mozambique
Tel: +258 84 312 4146

Namibia - Swakopmund

608 Nelson Mandela Avenue,
Swakopmund, Namibia
Tel +264 64 46 3677 /
+264 64 46 2720

Namibia - Windhoek

Cnr Nickle & Michelle McClean Street,
Prosperita, Windhoek, Namibia
Tel +264 61 425 350 /
+264 081 164 9806

Swaziland - Matsapha

Lot 814, King Mswati III Ave,
Matsapha, Swaziland
Tel +268 25 18 8360 /
+268 7668 5337

Tanzania - Dar es Salaam

Cnr Mwaikibaki Road & Kilimani
Close, Plot 1034/5 Mbezi Kawe,
Dar es Salaam, Tanzania
Tel +255 75 638 8115 /
+255 74 299 8022

Zambia - Kitwe

Plot 16, Karibu Business Park,
Kitwe, Zambia
Tel +260 966 880009 /
+ 260966 923 854

Zambia - Lusaka

Plot 397 A/3/B Kufue Road,
Lusaka, Zambia
Tel +260 968 491061 /
+ 260966 923 854

South African Branches

Ballito

Labora Terra Industrial Park,
Shakas Rock Road, Umhlali,
Ballito, KwaZulu Natal
Tel +27 (0) 32 947 9430

Bloemfontein

26 Tibbie Visser Street, Estoire
Small Holdings District,
Bloemfontein, Free State
Tel +27 (0) 51 432 5555

Cape Town

8 Rondevallei Road, Hagley,
Kuilsvier, Western Cape
Tel +27 (0) 21 528 6500

Durban South

16 Stroude Place, Isipingo,
KwaZulu Natal
Tel +27 (0) 31 902 2677

East London

5 Ray Craib Crescent,
Beacon Bay, Eastern Cape
Tel +27 (0) 43 748 2558

Gauteng

Poplar Crescent, Lords View
Industrial Park, Klipfontein,
Chloorkop X66, Gauteng
Tel +27 (0) 10 601 6313

George

10 Ring Road, George Industrial,
George, Western Cape
Tel +27 (0) 44 695 0294

Kathu

33 Kalk Street, Industrial Area,
Kathu, Northern Cape
Tel +27 (0) 53 723 2194

Lephalale

Rietspruit Plot 23, Portion 46,
Witkop Road, Lephalale, Limpopo
Tel +27 (0) 14 763 7982

Margate

Industrial Road, Margate,
KwaZulu Natal
Tel +27 (0) 39 317 1708

Nelspruit

Erf 379, Rocky Drift,
Mpumalanga
Tel +27 (0) 13 758 1036

Newcastle

6 Schonland Street, Riverside
Industrial Area, Newcastle,
KwaZulu Natal
Tel +27 (0) 34 375 7697

Pietermaritzburg

Market Road Ext, Mkondeni,
Pietermaritzburg, KwaZulu Natal
Tel +27 (0) 33 346 1767

Polokwane

62 Goud Street, Laboria,
Polokwane, Limpopo
Tel +27 (0) 15 293 0450

Port Elizabeth

4 Kendle Street, Neave Industrial
Area, Eastern Cape
Tel +27 (0) 41 453 2317

Richards Bay

111 Alluminia Alley, Alton Industrial
North, KwaZulu Natal
Tel +27 (0) 35 751 1140

Rustenburg

3 Ferro Street, Rustenburg,
North West Province
Tel +27 (0) 14 538 2540

Vereeniging

Cnr Telford & Van Riebeeck Street,
Duncanville, Gauteng
Tel +27 (0) 16 455 1611

Witbank

TP66 Geodesic Crescent, Marelden
Ext 3, Techno Park, Witbank,
Mpumalanga
Tel +27 (0)13 690 2833

Head Office

181 Barbara Road,
Elandsfontein, Gauteng
PO Box 669, Isando, 1660
Tel +27 (0) 11 842 4000



 **tifa-flex**

Waco Africa / Head Office: PO Box 669, Isando, 1600.
181 Barbara Road, Elandsfontein. Tel: 011 842 4000

 **form-scaff**

Technical Advice Centre 0800 20 50 29 / 011 842 4011
www.formscaff.com