

Product Catalogue
Support Work

FS **super-shore**



FS **form-scaff**

Formwork & Scaffolding
Solutions

We are
WACO



Form-Scaff is South Africa's leading supplier of formwork, falsework and scaffolding to the construction and civil engineering industries. Form-Scaff not only manufactures, hires and sells world-class products, but also provides the design skills, technical advice and support that comes with having 50 years experience and more than 30 branches locally and internationally.

We are Waco International

Form-Scaff is part of Waco International, a focused equipment rental and industrial services business with operations in Africa (South Africa and other sub-Saharan African countries), Australasia (Australia and New Zealand) and the United Kingdom.

The Group provides services in the areas of formwork, shoring and scaffolding, insulation, painting and blasting, hydraulics and suspended access platforms, relocatable modular buildings, portable sanitation products and integrated hygiene services.

Disclaimer:

Copyright in this catalogue vests in Form-Scaff, a division of Waco Africa (Proprietary) Limited ("Form-Scaff") and extends inter alia, to the making of copies in whole or in part without the prior written consent of Form-Scaff.

While every effort has been made to ensure the accuracy of the information in this catalogue, we cannot accept responsibility for any errors which may occur as a result of reliance on the contents of this catalogue and are not liable for any loss of any nature that may be incurred as a result of such reliance. Details of any of the products may change without prior notice.

The customer must ensure that 'good practice' is adopted on site by competent persons and that the products shown in this catalogue are erected, used and stripped in accordance with the relevant Codes of Practice and the OHS Act and Regulations 85 of 1993. This catalogue does not contain any design detail but lists and depicts the items available under this product range. The responsibility for design is the responsibility of the customer.

Note: The colours used in this document are for illustrative purposes only and may differ on actual products

Contents



super-shore

- 4 Super-Shores
- 6 Super-Shore Details
- 8 Super-Shore Connecting Plates
- 10 Connecting Brackets & Bracing
- 12 Tube Connecting Brackets & Couplers
- 14 Super-Shore Hydraulic Jacking Units
- 16 Super-Shore Dome Units

Contact Details

- 17 International Branches
- 17 South African Branches

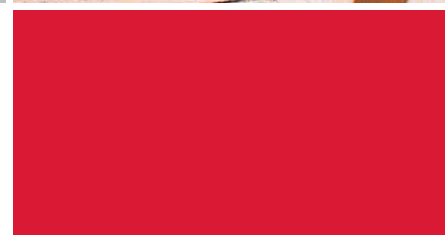
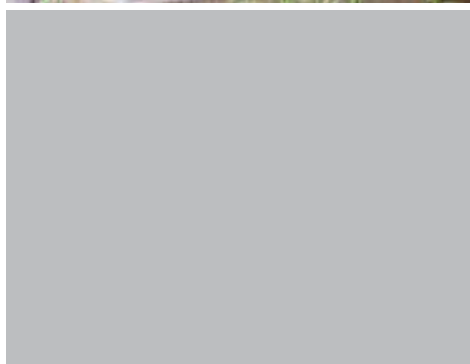



super-shore



Super-Shore Support Work

Form-Scaff's high load Super-Shore system provides the construction industry a support system able to accommodate higher load requirements while keeping the amount of equipment needed to minimum.

System Features

- Up to 100 kN loading capacity
- Modular design
- Unique bracing components



super-shore

General Assembly

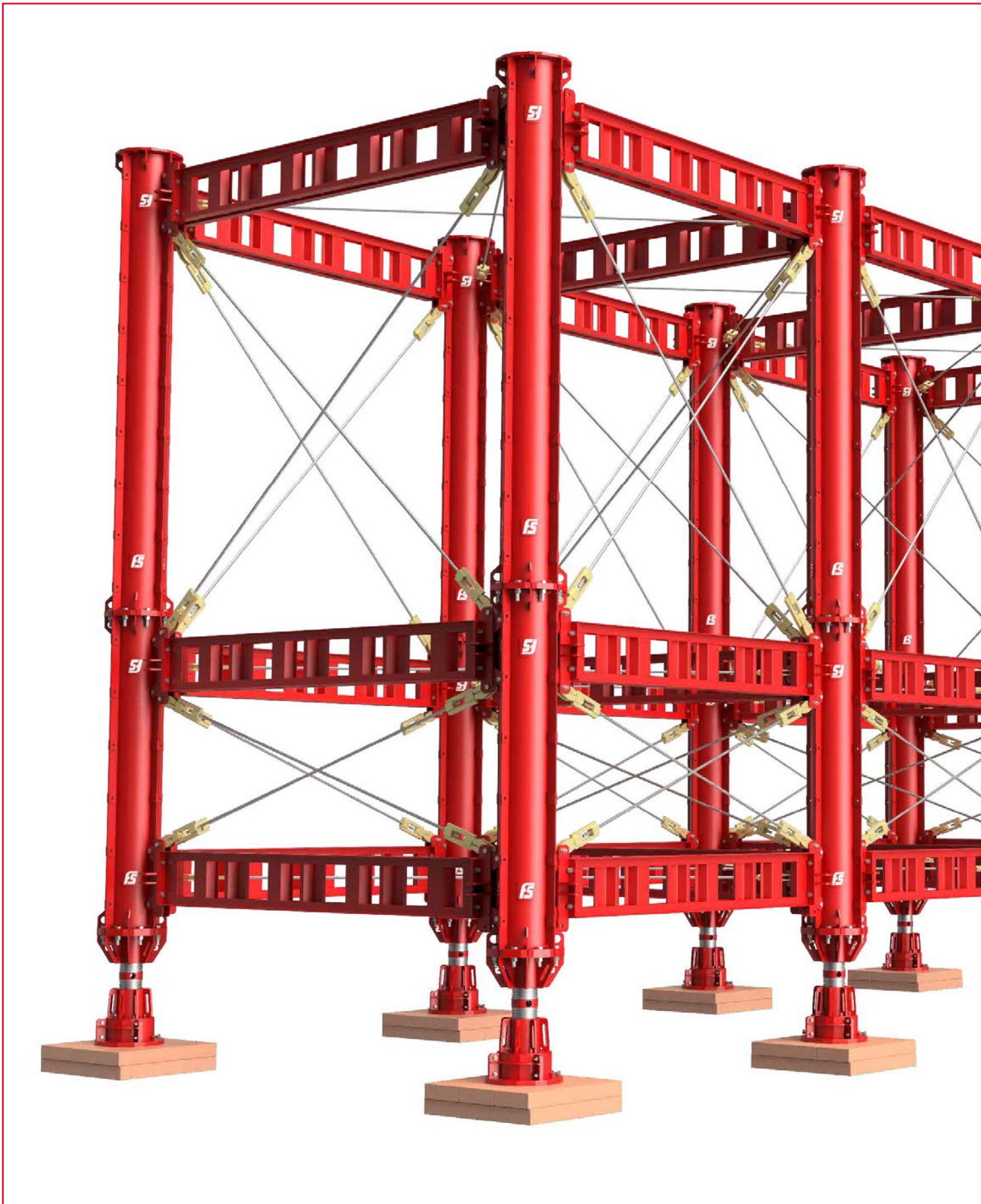

Super-Shores

Super-Shores

Super-Shores are the main vertical support component of the Super-Shore System

CODE	DESCRIPTION	MASS(kg)
5320001	Super-Shore 900	78.0
5320002	Super-Shore 1800	126.2
5320003	Super-Shore 2700	174.4



8 Off $\varnothing 22$ mm Holes

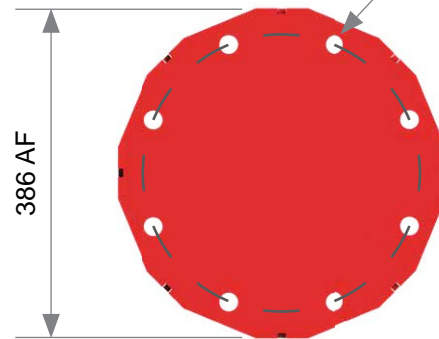

Super-Shore End View

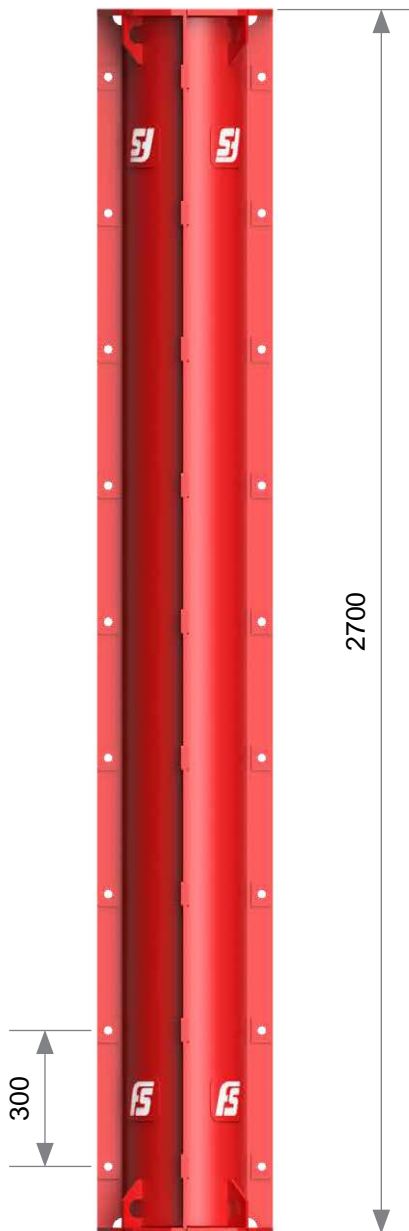

Super-Shore 2700

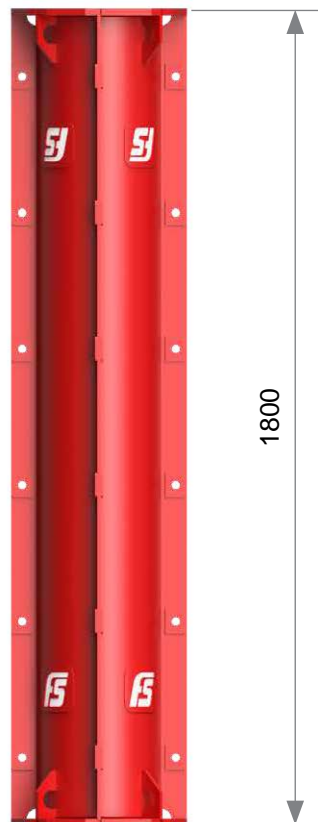

Super-Shore 1800



Super-Shore 900



Free Standing Single Prop Working Load Limits (kN)				
Effective Length KL (m)	Load Eccentricity (mm)			
	e=0	e=10	e=25	e=50
0.9	1180	1050	825	680
1.8	1120	1040	810	665
2.7	1020	1020	780	645
3.6	905	990	750	615
4.5	795	940	700	580
5.4	690	880	650	540
6.3	595	790	590	490
7.2	520	690	530	450
8.1	450	690	470	400
9.0	390	500	410	360
9.9	340	425	350	320
10.8	300	370	320	280
11.7	270	320	280	255
12.6	235	280	240	230
13.5	210	250	220	205
14.4	190	210	195	180
15.3	170	190	180	165
16.2	150	160	160	150
17.1	140	140	145	135
18.0	130	130	130	125
18.9	120	120	115	115
19.8	110	110	100	110
20.7	100	105	105	100
21.6	90	100	90	85

1kN = 100 kg

Application - Super-Shore To Super-Shore Connection

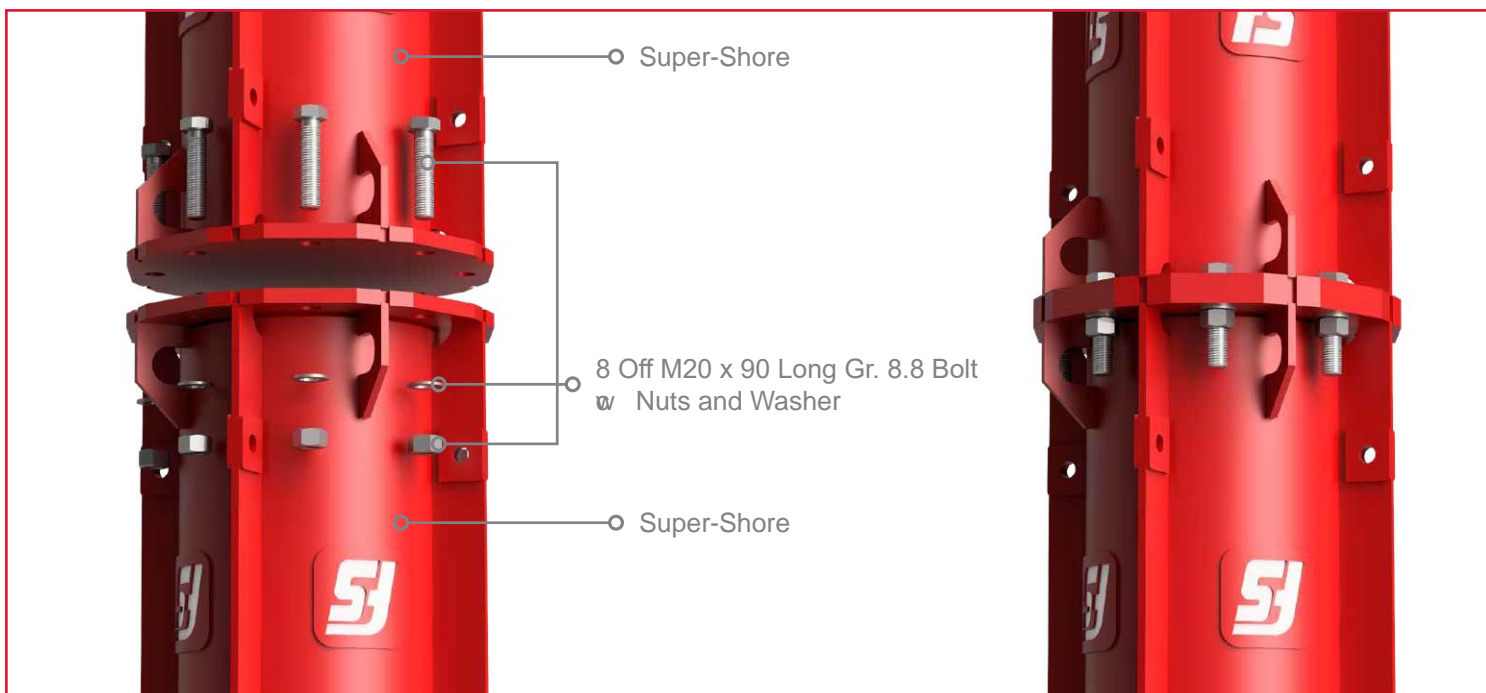

Super-Shore Jacks

Super-Shore Jacks

Super-Shore Jacks are bolted on the ends of Super-Shores to provide vertical height adjustment.

CODE	DESCRIPTION	MASS(kg)
5320004	Super-Shore Jack	97.9



Super-Shore Jack Working Load Limits (kN)			
Load Eccentricity (mm)	Side Load (kN)	Jack Extension (mm)	WLL (kN)
0	0	610	1150
10	10	610	950
10	30	610	900
10	50	610	750
10	50	515	850

1 kN = 100 kg

Application - Super-Shore Jack To Super-Shore Connection

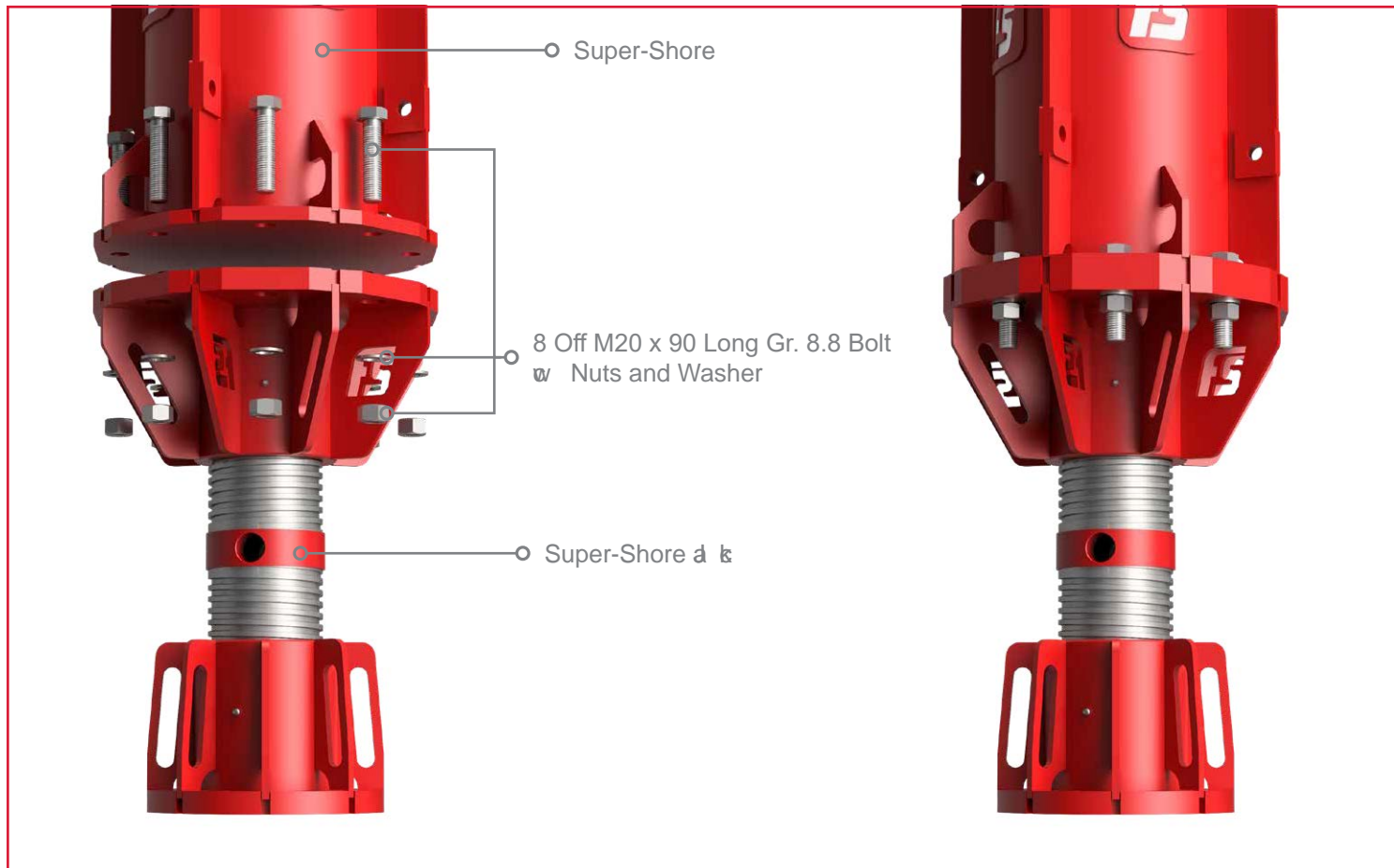



Super-Shore Sand Jacks

The Super-Shore system is placed on top of Super-Shore Sand Jacks that have fine sand placed in them that is later blown out using compressed air to provide a "Quick Strip" mechanism.



CODE	DESCRIPTION	MASS(kg)
5320005	Super-Shore Sand Jack	26.7

Application - Super-Shore Sand Jack



○ Super-Shore Jack

○ Super-Shore Sand Jack



○ Super-Shore Jack

○ Super-Shore Sand Jack

○ Fine Sand

Super-Shore Connecting Plates

Super-Shore Vertical Bracing Plate

Super-Shore Vertical Bracing Plates are connection plates used to brace Super-Shores vertically in close clusters creating batteries.

CODE	DESCRIPTION	MASS(kg)
5320008	Super-Shore Vertical Bracing Plate	4.8



Application - Super-Shore Vertical Bracing Plate Connection



Super-Shore Battery Plates

Super-Shore Battery Plates connect the ends of Super-Shores in different configurations providing a secure lateral joint.

CODE	DESCRIPTION	MASS(kg)
5320006	Super-Shore Battery Plate Double	21.5
5320007	Super-Shore Battery Plate Triple	32.6



Super-Shore Battery Plate Double



Super-Shore Battery Plate Triple

Application - Super-Shore Battery Plate Connections

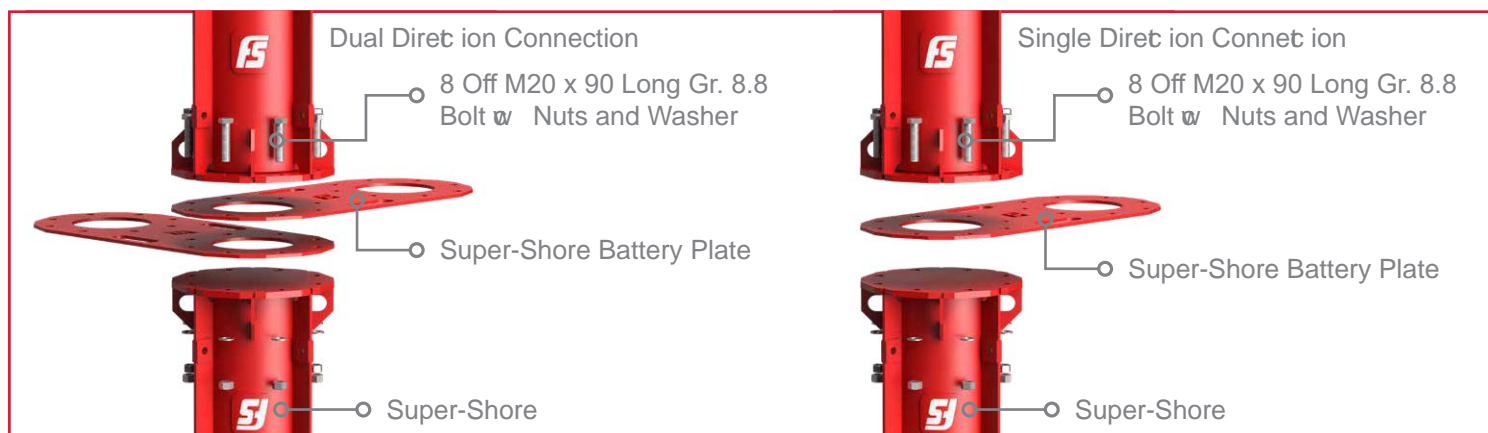



Application - Super-Shore Battery Configurations

2 Leg Super-Shore Battery
Single Direct Connection



3 Leg Super-Shore Battery
Single Direct Connection



4 Leg Super-Shore Battery
Dual Direct Connection



6 Leg Super-Shore Battery
Dual Direct Connection



9 Leg Super-Shore Battery
Dual Direct Connection



Connecting Brackets & Bracing

Super-Shore Soldier Connecting Brackets

Super-Shore Soldier Connecting Brackets are bolted to Super-Shores and provide a connection point for Form-Soldiers to create lateral members that space the Super-Shores and keep them in a vertical position

CODE	DESCRIPTION	MASS(kg)
5320080	Super-Shore Soldier Connecting Bracket	15.6

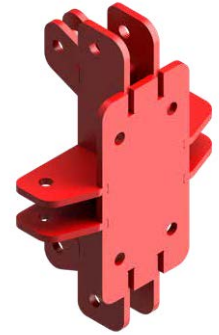

Form-Soldiers

Form-Soldiers provide the lateral spacing and vertical stability of the Super-Shores

CODE	DESCRIPTION	MASS(kg)
5405011	Form Soldier 600 Extension	20.4
5405012	Form Soldier 900 Extension	26.2
5405001	Form Soldier 1200	32.2
5405002	Form Soldier 1500	38.5
5405003	Form Soldier 1800	44.8
5405004	Form Soldier 2100	51.1
5405005	Form Soldier 2400	57.4
5405006	Form Soldier 2700	63.6
5405007	Form Soldier 3000	69.9
5405008	Form Soldier 3300	76.2
5405009	Form Soldier 3600	82.5
5405014	Form Soldier 3900	82.1

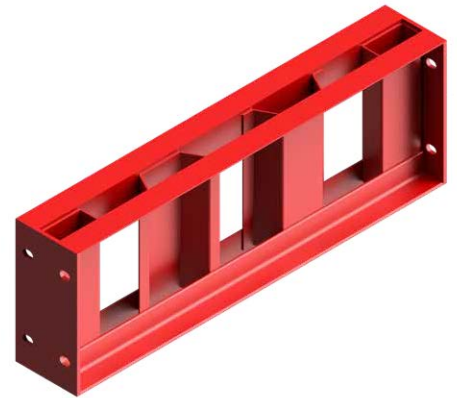

Dywidag Tensioner G15

Dywidag Tensioners are used to cross brace the Super-Shore system in both the vertical and lateral direction providing a stable frame.

CODE	DESCRIPTION	MASS(kg)
5405118	Dywidag Tensioner G15	3.8

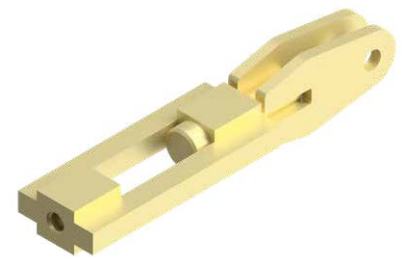

Dywidag Bar 15 Dia

Dywidag bar is a rope type threaded Tie bar used in the Super-Shore system as cross bracing tensioning bars

CODE	DESCRIPTION	MASS(kg)
5405075	Dywidag Bar 15 Dia (Per m)	1.5





Application - Soldier Connecting Brackets & Form Soldier Connection

Super-Shore Soldier Connecting Bracket Connection To Super-Shore

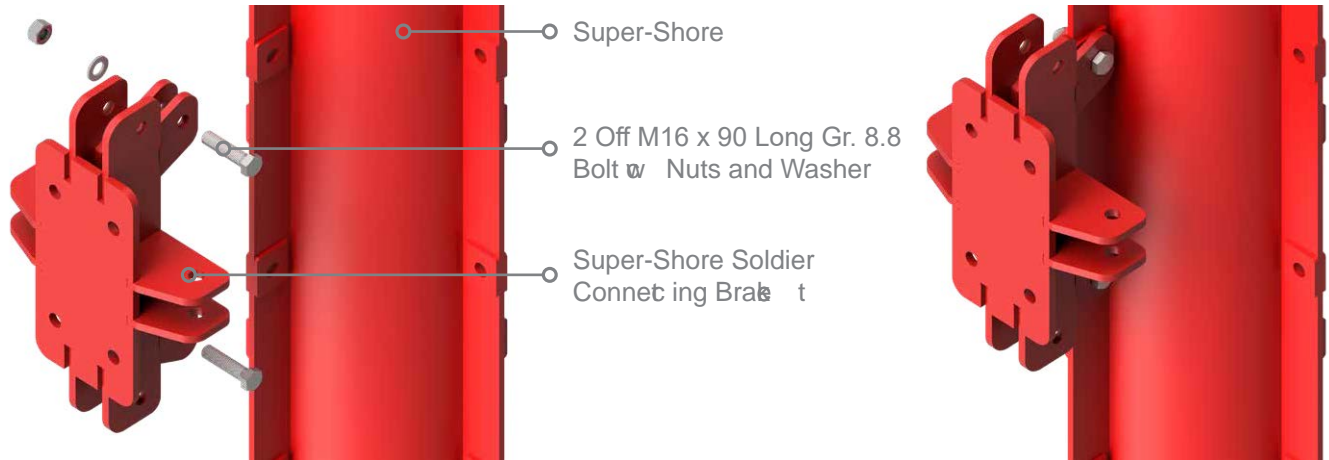

Form Soldier Connection To Super-Shore Soldier Connecting Bracket

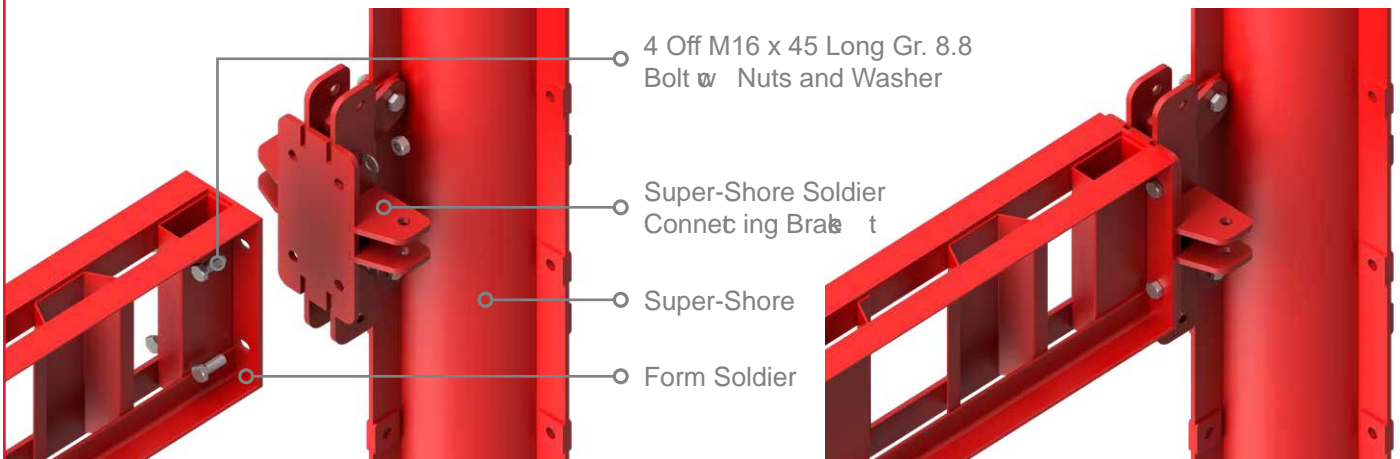

Application - Dywidag Tensioner To Soldier Connecting Bracket Connection

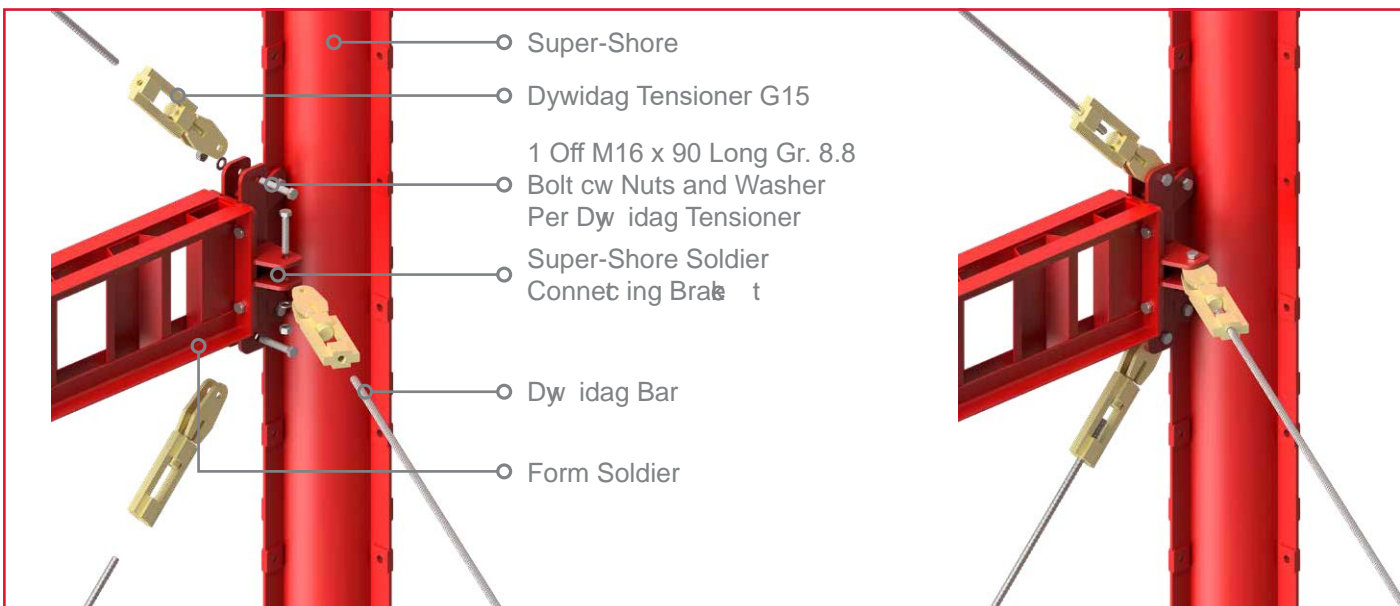

Tube Connecting Brackets & Couplers

Super-Shore Tube Connecting Bracket

Super-Shore Tube Connecting Brackets are bolted to the ends of Super-Shores and along with half Couplers allow for Ø48.4 tubes to be used as bracing and tie bars on the Super-Shore System.

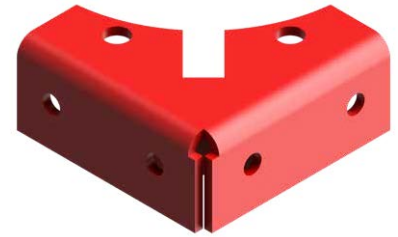

CODE	DESCRIPTION	MASS(kg)
5320081	Super-Shore Tube Connecting Bracket	4.8

Couplers

Couplers are used to secure scaffold tubes to one another as well as to other components or in combination.

CODE	DESCRIPTION	MASS(kg)
1905050	Coupler Swivel Half 50	0.5
1905059	Coupler Swivel 50 x 50	1.5
1905016	Coupler 90 Deg 50 x 50	1.5



Coupler Swivel Half



Coupler Swivel



Coupler 90 Deg

Assembly - Super-Shore Tube Connecting Bracket cw Half Swivel Couplers

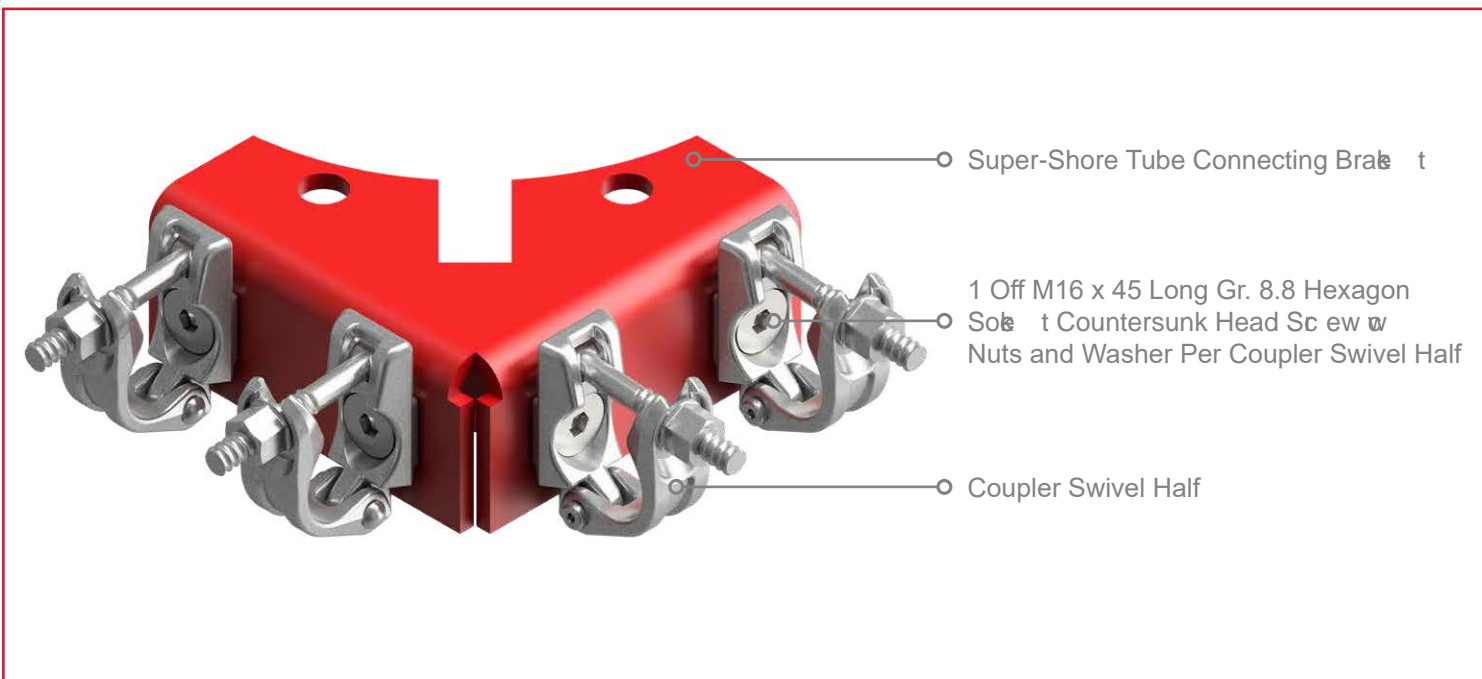



Application - Super-Shore Tube Connecting Bracket To Super-Shore Connection

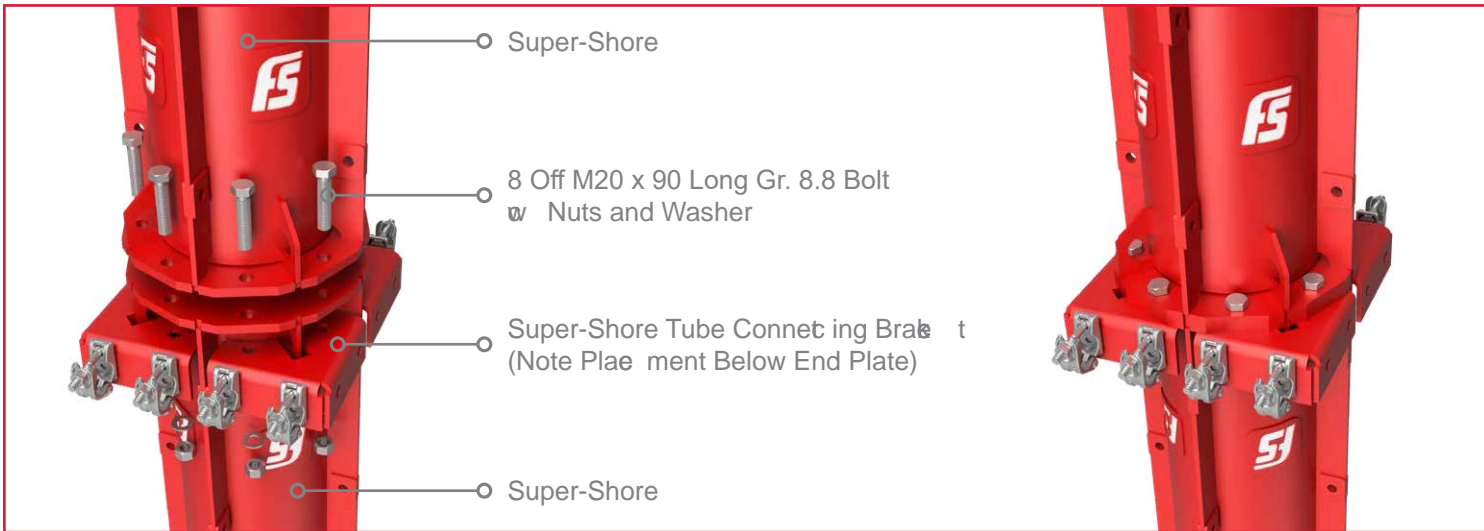

Application - Super-Shore Tube Connecting Bracket Tube Connections

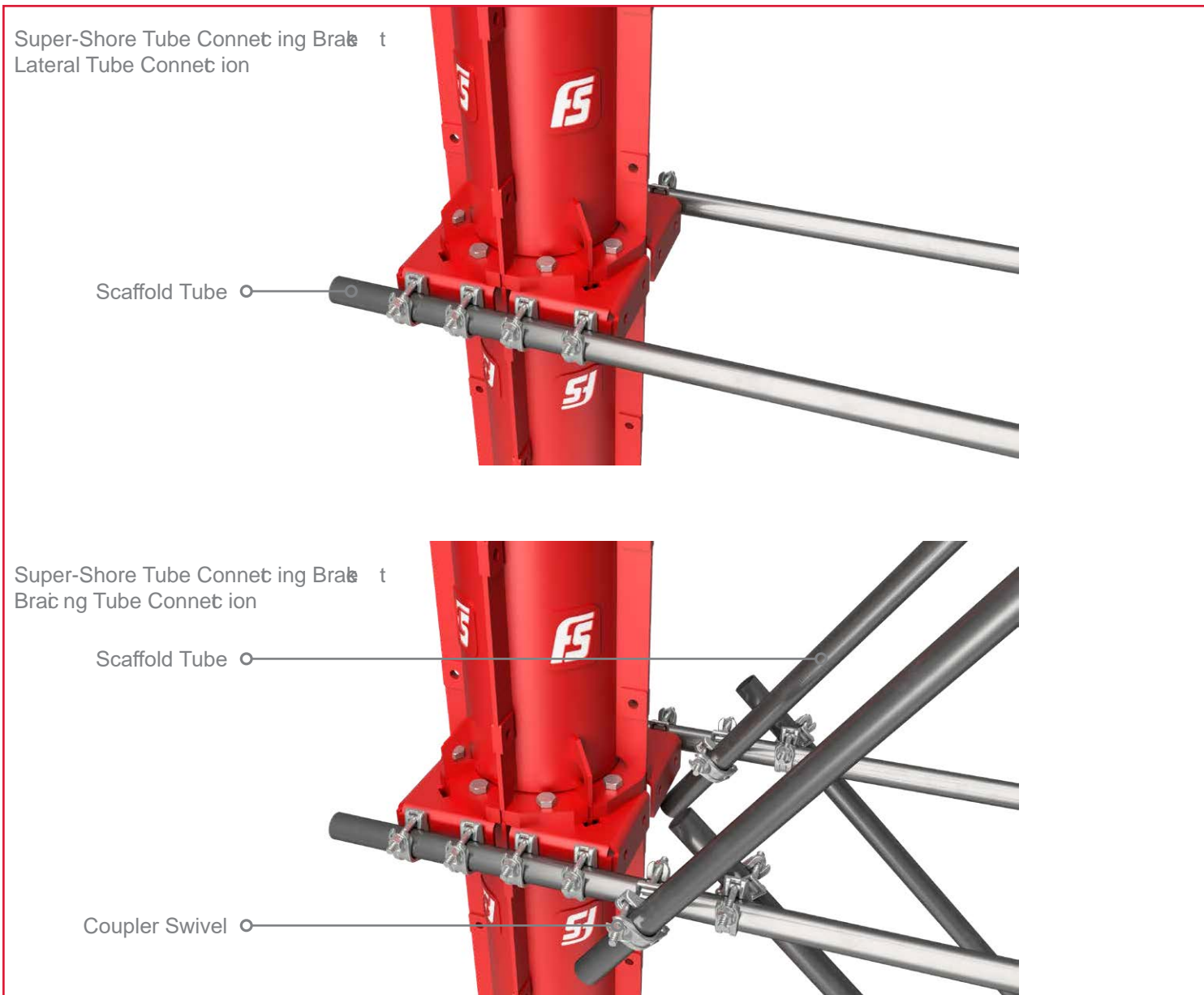

Super-Shore Hydraulic Jacking Units

Super-Shore Hydraulic Jacking Units

Super-Shore Hydraulic Units allow the safe and precise vertical jacking and lowering of structures where maintenance and realignment may be required.

CODE	DESCRIPTION	MASS(kg)
5320103	Super-Shore Hydraulic Jacking Unit	146.2

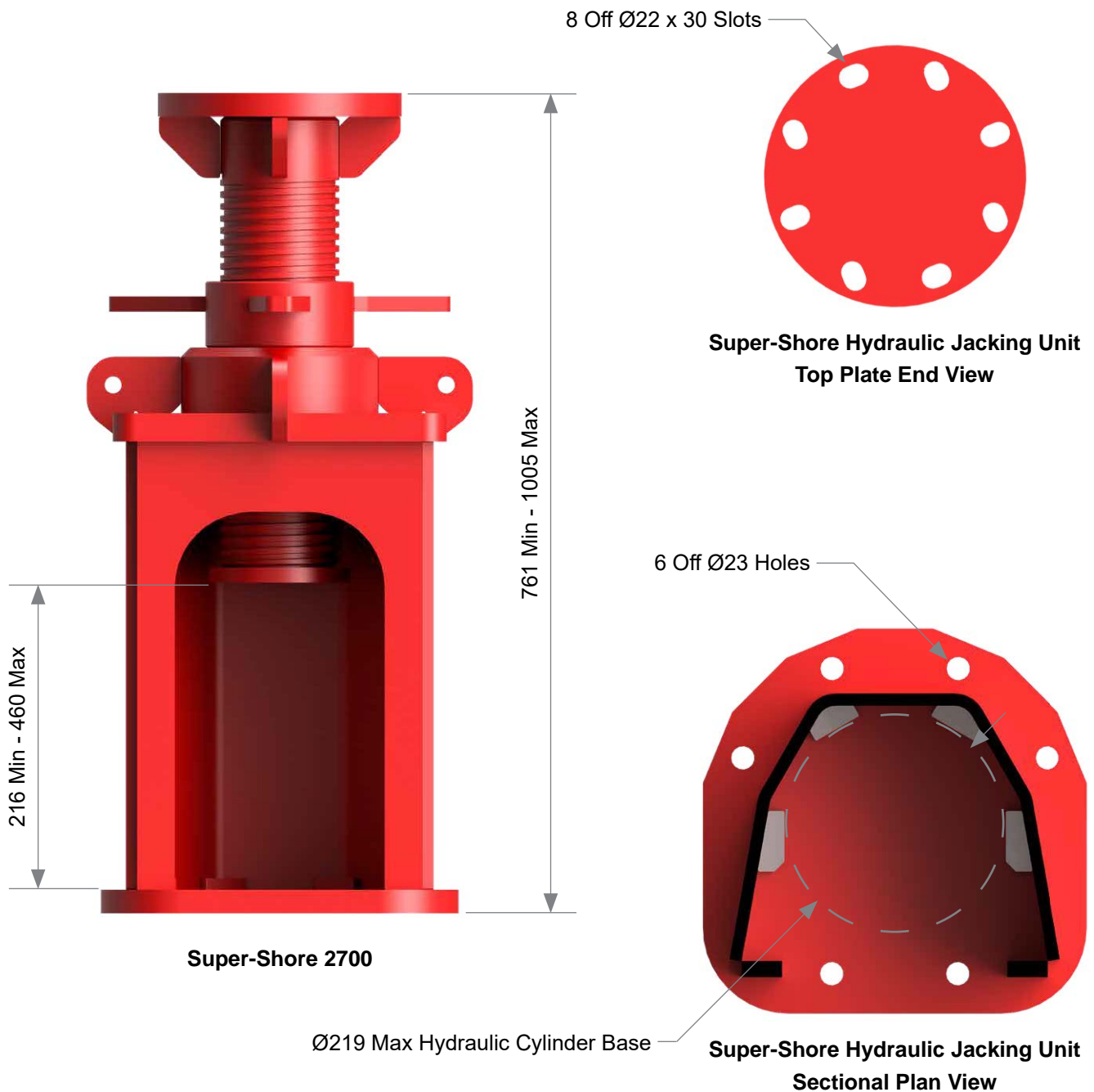



Application - Super-Shore Hydraulic Jacking Unit Connections

Super-Shore Hydraulic Jacking Unit - Connection To Super-Shore

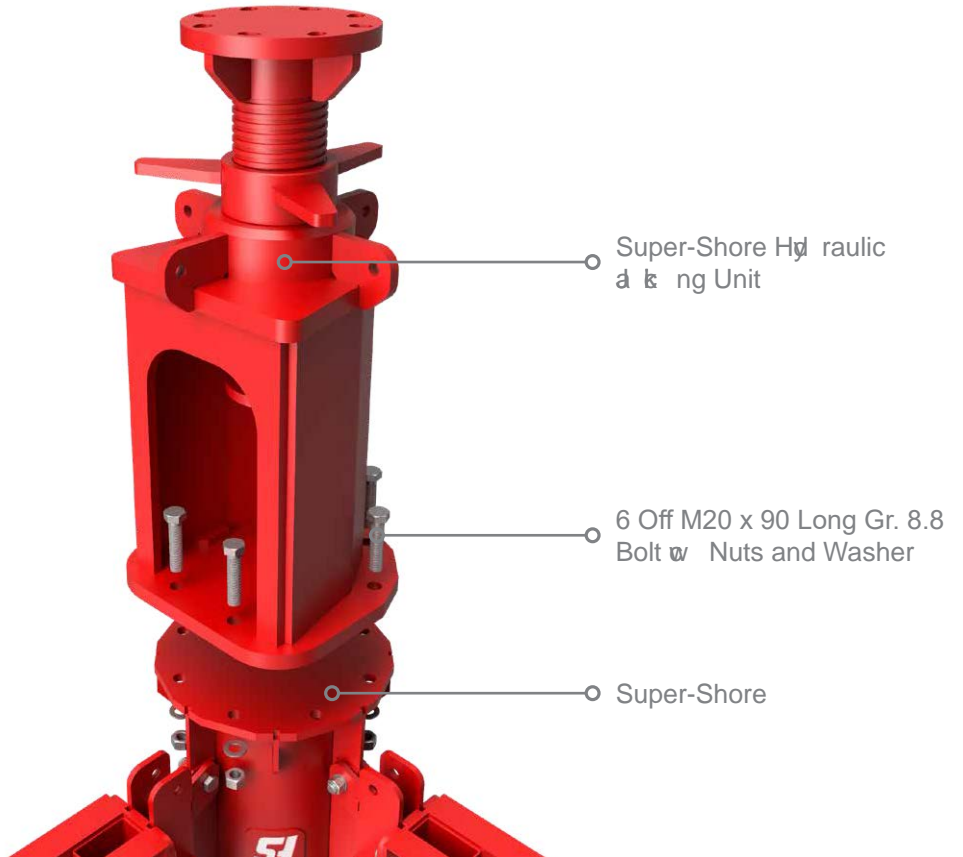

Super-Shore Hydraulic Jacking Unit - Bracing Connections

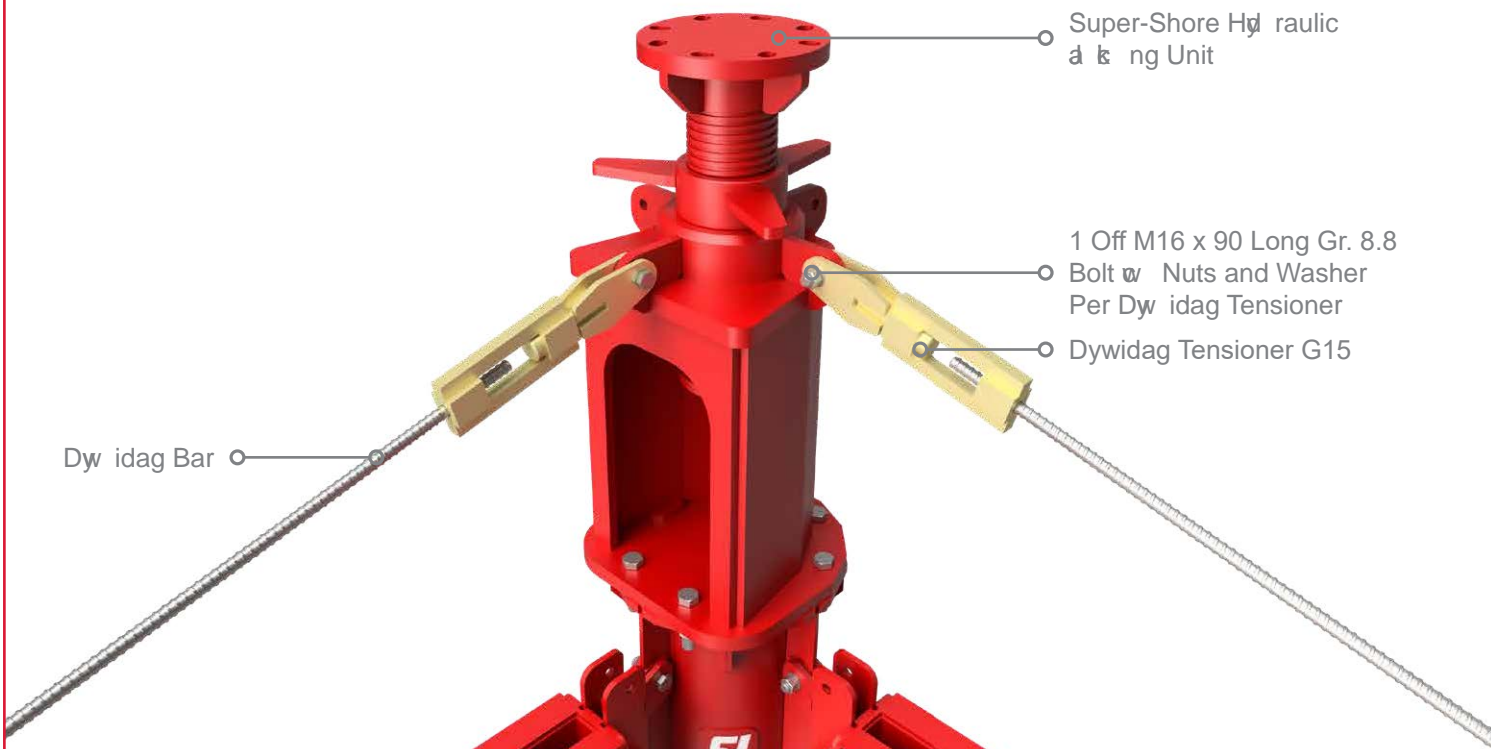

Super-Shore Dome Units

Super-Shore Dome Units

Super-Shore Dome Units are used to compensate for the slight miss alignment of supported bearers

CODE	DESCRIPTION	MASS(kg)
5320102	Super-Shore Dome Unit	32.8

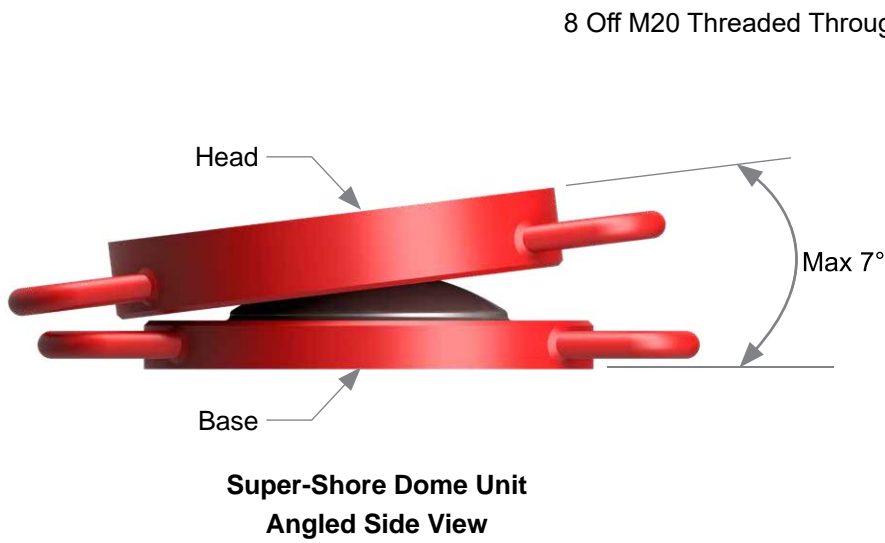

8 Off M20 Threaded Through Holes

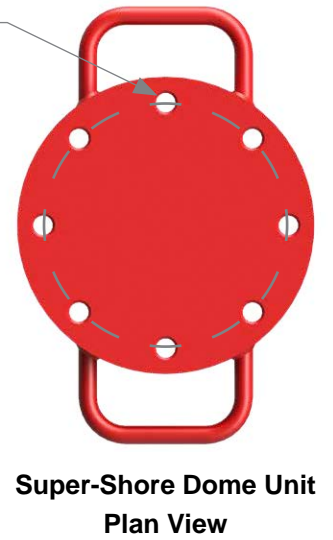

Application - Super-Shore Dome Unit Connection

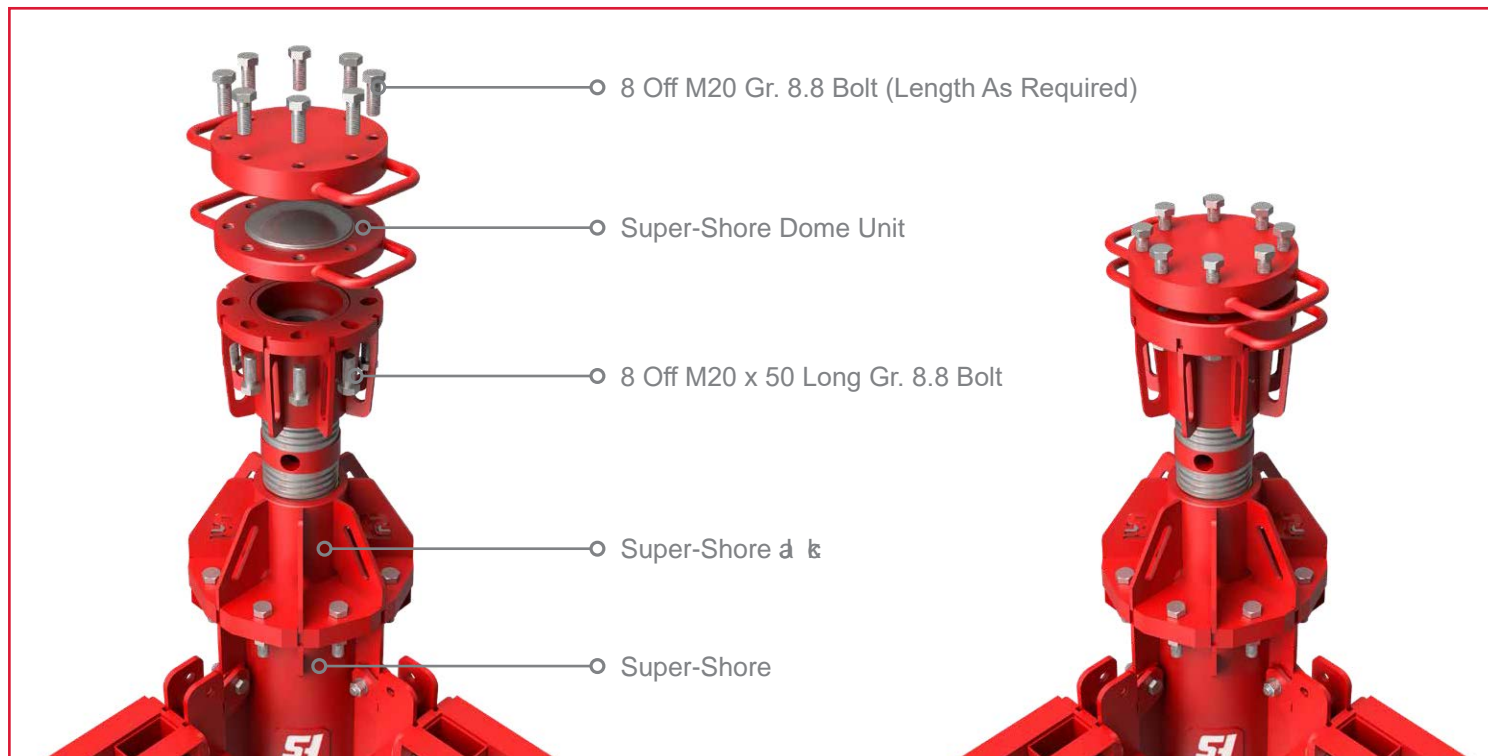

International Branches

Botswana - Gaborone

Plot 31364, Gaborone North,
Gaborone, Botswana
+267 396 2000

Ghana - Accra

Plot 29, Off Spintex Road, Tema
Motorway Industrial Area, Accra, Ghana
+233 303 973 722

Mauritius - Port Louis

Anse Courtois Street, Montebello,
Pailles, Mauritius
+230 286 6176

Mozambique - Maputo

Belulane, Pare lla 15988, Boane
Matola Rio, Maputo, Mozambique
+258 84 365 0162

Mozambique - Palma

N'Cumbi Road No. R762, Palma,
Mozambique
+258 86 109 6443 / +258 84 774 3788

Mozambique - Pemba

Estrada Nacional EN106, Muxara
Pemba, Cabo Delgado, Mozambique
+258 84 312 4146

Namibia - Windhoek

Cnr Nik e & Mib elle, Mē lean Street,
Prosperita, Windhoek Namibia
+264 61 425 350

Eswatini - Matsapha

Lot 796, King Mswati III Avenue West & Usuthu
Cresent, Matsapha, Eswatini
+268 25 18 8360 / +268 7668 5337

Tanzania – Dar es Salaam

Cnr Mwaikibaki Road & Kilimani Close
Plot 1034/5 Mbezi Kawe
Dar es Salaam, Tanzania
+255 74 299 8022

Zambia - Kitwe

12867 Chingola Road, Saloba Business Park
Chimwemwe, Kitwe, Zambia
+260 966 880 009

Zambia - Lusaka

Plot 397 A/3/B Kufue Road
Lusaka, Zambia
+260 968 491 061

Zambia - Solwezi

Suite 12, Kansanshi Road, Plot No 2945,
Solwezi, Zambia
+260 768 935 762

South African Branches

Ballito

Labora Terra Industrial Park
Shab s Rok Road, Umhlali
Ballito, KwaZulu Natal
+27 (0) 32 947 9430

Bloemfontein

26 Tibbie Visser Street
Estoire Small Holdings Distrib
Bloemfontein, Free State
+27 (0) 51 432 5555

Cape Town

8 Rondevallei Road, Hagley
Kuilsrivier, Cape Town
+27 (0) 21 528 6500

Durban

16 Stroude Plae , Isipingo
KwaZulu Natal
+27 (0) 31 902 2677

East London

5 Ray Craib Cresen t,
Beao n Bay North
Beao n Bay, Eastern Cape
+27 (0) 43 748 2558

Midrand

Poplar Cresen t, Lords View
Industrial Park, Klipfontein
Chloorkop X66, Gauteng
+27 (0) 10 601 6313

George

10 Bridge Road, George Industrial
George, Western Cape
+27 (0) 44 695 1037

Kathu

33 Kalk Street, Industrial Area
Kathu, Northern Cape
+27 (0) 53 723 2194

Margate

Industrial Road, Margate
KwaZulu Natal
+27 (0) 39 317 1708

Mbombela

Erf 379, Rok Drift
White River, Mbombela
+27 (0) 13 758 1036

Newcastle

6 Sbonland Street
Riverside Industrial Area
Newcastle, KwaZulu Natal
+27 (0) 34 375 7697

Polokwane

62 Goud Street,
Polokwane Ext 8, Limpopo
+27 (0) 15 293 0450

Gqeberha

4 Kendle Street
Neave Industrial Area
Eastern Cape
+27 (0) 41 453 2317

Rib ards Bay

111 Alluminia Alley St,
Alton Industrial North, Rib ards Bay
KwaZulu Natal
+27 (0) 35 751 1140

Rustenburg

3 Ferro Street, Rustenburg
North West Province
+27 (0) 14 538 2540

Emalahleni

TP66 Geodesic Cresent
Marelden Ext 3, Techno Park
Witbank Mpumalanga
+27 (0) 13 690 2833

Head Office

181 Barbara Road,
Elandsfontein, Gauteng
PO Box 669, Isando, 1660
Tel +27 (0) 11 842 4000

 **super-shore**

Waco Africa / Head Office: PO Box 669, Isando, 1600.
181 Barbara Road, Elandsfontein.
Tel: 011 842 4000

 **form-scaff**

Tel: nia | Adv e Centre 0800 20 50 29 / 011 842 4011

www.formscaff.com